

USFilter

**STRANTROL[®] SYSTEM5F
TECHNICAL GUIDE**

Stranco Products
P.O. Box 389
Bradley, IL 60915
866.766.5987 *phone*
815.932.8154 *phone*
815.932.1760 *fax*
<http://www.strancoaquatics.com>
©2004USFilter Corporation

Mounting the System5F **Chapter 1**

Plumbing Flowcell **Chapter 2**

Assembling the Flowcell.....	2-1
Plumbing the Flowcell	2-2
Checking the Flowcell	2-3

System Startup **Chapter 3**

System5F Board Types.....	3-1
Running Power to System5F.....	3-2
CPU Board Connections	3-4
Wiring Devices to Relays in the System5F.....	3-8
Warning.....	3-9
Connecting Flowcell to System5F	3-12
pH, HRR and Temperature	3-12
Water Ground	3-12
Flow Switch.....	3-12
Optional: Signal Transmitter	3-13
Input Board Connections.....	3-15
Output Board 4-20mA Connections	3-17
Serial Input/Output Connections on the Modem Board	3-19
Printer Board Connections (Optional)	3-20
Pin Connections Between System5F Terminal and Printer DB25 Pin Connector.....	3-20
Common Installation Errors.....	3-20
Review of common problems and solutions.....	3-20
Feed devices will not start.....	3-21
The HRR or pH Displays Fluctuate Rapidly	3-21
The Chlorine Reading is WAIT	3-21
Menu Access	3-22
Quick Reference Guide - Functions & Access Levels.....	3-23
Data Logging.....	3-24
Event.....	3-24
Event Buffer	3-24
High/Low Resolution Logs	3-24
Control Logic & Functionality.....	3-26
System Startup	3-26
Temperature Option.....	3-26
Enabling the Temperature Control Option	3-26
Ozone Option.....	3-27
Enabling the Ozone Option.....	3-27
Parts & Supplies.....	3-28
Maintenance.....	3-28
Cleaning The Sensors	3-28

Control Tuning **Chapter 4**

pH Control Options	4-1
Chlorine or Bromine Control Options	4-2
Alarm Warning Bands	4-3
Availability	4-3
Rules/Logic	4-3
Example — High Alarm Warning Band	4-4
Example — Low Alarm Warning Bands	4-5

Recorder Outputs **Chapter 5**

4-20 mA Outputs	5-1
4-20 mA Linear Relationship	5-2

Menu Options **Chapter 6**

Menu Tree v 5.10 — Reference Guide	6-1
Menu Tree v 5.10 — Definitions	6-7

Sensor Wash Option **Chapter 7**

Sensor Wash	7-1
Configure Sensor Wash	7-1
Programming Sensor Wash	7-2
Menu Displays	7-3
Example	7-4

Superchlorination Option **Chapter 8**

Superchlorination Programming	8-1
Superchlorination Functionality	8-2
Example	8-3

Calculate LSI Setup Option **Chapter 9**

LSI Programming	9-1
LSI	9-1
Ryznar Index	9-1
Dosage Calculated	9-1
Example	9-2

Alternate HRR Setpoint Option **Chapter 10**

Alternate HRR Setpoint Programming	10-1
Alternate HRR Setpoint Functionality	10-2

Dechlorination Setpoint **Chapter 11**

Dechlorination Programming 11-1
Dechlorination Functionality 11-2

Cl/Br Booster Option **Chapter 12**

Cl/Br Booster Functionality 12-1

Communication Capabilities **Chapter 13**

Communication Functionality 13-1
 Direct Connection 13-1
 Data Modem Connection 13-1
 Voice Data Modem Connection (optional) 13-1
 Programming Call Out Feature 13-2
 Programming Fax Out Feature 13-3
 Programming Pager Out Feature 13-4
 Voice Data Modem Terminology & Operations 13-5
 Call into the Voice Data Modem for Reports 13-8
 Setup the Voice Data Modem to Call Out 13-8
 Customize the Ring Pickup Value 13-9
 Customize the Call Out Pre-Delay 13-9
 Customize the Delay 13-9
 The FCC and Your Voice Data Modem 13-10

Note: Please pay particular attention to the warning notices found on the following pages and throughout this manual.

NEVER OVERRIDE SAMPLE FLOW SWITCH

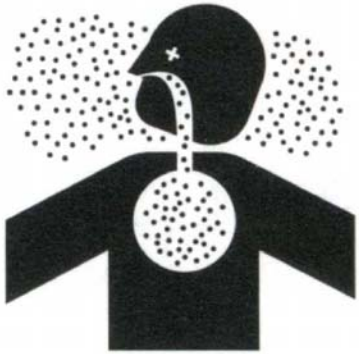
	<p>! WARNING</p> <p>NEVER OVERRIDE SAMPLE FLOW SWITCH</p> <p>Uncontrolled feeding of chemicals can result in injury or death.</p> <p>Sample flow switch is a critical safety device which prevents uncontrolled chemical feed.</p> <p>Follow instructions carefully.</p>
---	--

Flow switches are provided with all Strantrol controllers and are an integral safety device to prevent the uncontrolled feed of chemicals, which could cause personal injury or death. The flow switch should NEVER be bypassed, even temporarily, as this critical safety device will not be available to protect the swimmers.

TEST FLOW SWITCH FUNCTION

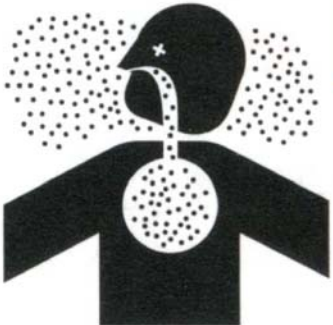
	<p>! WARNING</p> <p>TEST FLOW SWITCH FUNCTION</p> <p>Uncontrolled feeding of chemicals can result in injury or death.</p> <p>Assure flow switch prevents chemical feed in any circulation NO-FLOW or backwash condition.</p> <p>Follow instructions carefully.</p>
---	--

If flow switch does not stop and remain stopped during backwash, no-flow, or very low flow conditions, the controller cannot prevent the uncontrolled feed of chemicals, which could cause personal injury or death.

Testing of the flow switch installation is essential to assure the flow switch stops, remains stopped, and controller shows “NO-FLOW ALARM” within 20 seconds, whenever filter is in backwash or circulation flow stops. If the flow switch does not stop completely, plumbing corrections or the installation of additional safeguards will be necessary to avoid uncontrolled chemical feed.

NEVER CONNECT FEEDER DIRECTLY TO POWER SOURCE

	<p>! WARNING</p> <p>NEVER CONNECT FEEDER DIRECTLY TO POWER SOURCE</p> <p>Uncontrolled feeding of chemicals can result in injury or death.</p> <p>Chemical metering pumps must be connected to controller to enable safety controls.</p> <p>Follow instructions carefully.</p>
---	---

If the chemical feeders are connected to a wall outlet, the safety devices integral to your Strantrol controller, and to the safe feeding of chemicals, will be bypassed. It is very important that the chemical feeders are connected to the controller and never to a wall outlet. If the chemical feeders are connected to a wall outlet and feeding continuously, when the flow of water to the pool stops due to filter backwash, the circulation pump losing prime or other causes, potentially hazardous concentrations of chemicals can be fed into pool or spa.

ALWAYS USE ANTI-SIPHON DEVICES

	<p>! WARNING</p> <p>ALWAYS USE ANTI-SIPHON DEVICES</p> <p>Uncontrolled feeding of chemicals can result in injury or death.</p> <p>Anti-siphon devices must be installed to prevent uncontrolled chemical feed.</p> <p>Follow instructions carefully.</p>
---	--

If a vacuum is created in the water circulation line and no anti-siphon device is installed on the chemical feeders, potentially hazardous concentrations of chemicals can be drawn into pool or spa. Always use injection check valves and anti-siphon valves in the chemical feed lines to prevent this situation from occurring.

ELECTRICAL SURGES CAN DAMAGE YOUR CONTROLLER

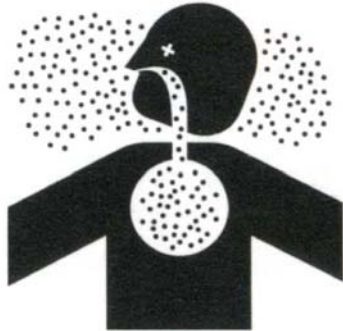
	<p>⚠ WARNING</p> <p>ELECTRICAL SURGES CAN DAMAGE YOUR CONTROLLER</p> <p>A damaged controller could feed chemicals in an uncontrolled manor.</p> <p>Uncontrolled feeding of chemicals can result in injury or death.</p> <p>If you suspect your controller is not operating properly, disconnect it from control of chemical feed.</p>
---	---

Strantról controllers, like all modern electronic devices can be damaged by severe electrical spikes and surges (think 'lightning'). Every effort has been made to harden your Strantról controller against such surges, but no precautions are 100% effective. Additional surge protection can be installed at time of installation, but even that is not a guarantee that surge damage will not occur. If surge damage occurs, chemicals could be fed to your pool or spa, continuously with no safety controls. If you inspect your Strantról after a possibly damaging power surge (thunderstorm or power outage) and suspect the controller is not operating properly, disconnect the chemical feeders at once, and contact your Strantról dealer for service.

DISCONNECT AND LOCKOUT POWER BEFORE SERVICING

	<p>⚠ WARNING</p> <p>Hazardous Voltage Enclosed</p> <p>Voltage or current hazard sufficient to cause shock, burn, or death.</p> <p>Disconnect and lockout power before servicing.</p>
---	--

Line voltage (120/240VAC) can be present inside the Strantról controller and caution should be used to prevent electrical shock, burns or electrocution. Be sure electric power is disconnected before opening the cover of any Strantról. Follow all local safety policies, procedures and electrical codes, to prevent injury from electrical hazards, before opening the cover of this controller. If you are not trained and comfortable performing work on electrical equipment, contact a licensed electrician to perform the work.

WARNING REGARDING CIRCULATION PUMP INTERLOCK

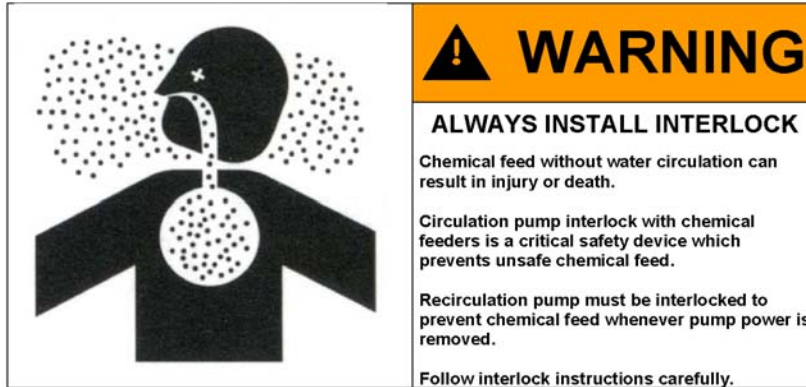

WARNING

ALWAYS INSTALL INTERLOCK

Chemical feed without water circulation can result in injury or death.

Circulation pump interlock with chemical feeders is a critical safety device which prevents unsafe chemical feed.

Recirculation pump must be interlocked to prevent chemical feed whenever pump power is removed.

Follow interlock instructions carefully.

If concentrated Chlorine and Acid are combined, chlorine gas is released. Chlorine gas causes severe irritation to lungs and can be toxic in certain situations.

If water is not flowing in the return line to the pool, and both these concentrated chemicals are allowed to combine in still water, a chlorine gas bubble will be created. When the flow eventually resumes to the pool, the chlorine bubble would then be flushed into the pool and released into the air around the pool, beginning at the water surface. To help prevent this situation, a chemical pump interlock must be installed. An interlock removes power from the chemical feed pumps whenever the power to the recirculation pump power is switched off

WARNING REGARDING CONNECTING pH & CHLORINE OR BROMINE FEEDERS

	<p>⚠ WARNING</p>
<p>DO NOT REMOVE THIS LABEL</p>	<p>ONLY CONNECT A pH FEEDER TO THIS OUTLET.</p> <p>Connecting a Chlorine/Bromine feeder to this outlet can cause chemical interactions that may cause personal injury or death.</p> <p>Insure feeders are connected properly to avoid hazardous chemical feed conditions.</p> <p>Never connect Chlorine/Bromine feeder to this connector.</p> <p>Strantrol pH Sensors are color coded as YELLOW.</p>

	<p>⚠ WARNING</p>
<p>DO NOT REMOVE THIS LABEL</p>	<p>ONLY CONNECT A CHLORINE/BROMINE FEEDER TO THIS OUTLET.</p> <p>Connecting a pH feeder to this outlet can cause chemical interactions that may cause personal injury or death.</p> <p>Insure feeders are connected properly to avoid hazardous chemical feed conditions.</p> <p>Never connect pH feeder to this connector.</p> <p>Strantrol Chlorine/Bromine Sensors are color coded as BLUE.</p>

Oxidizers (Chlorine or Bromine), acids (Muratic, Carbon Dioxide, CO₂) and caustics (Sodium Hydroxide, Caustic Soda, Soda Ash) are common chemicals used to automatically maintain safe and healthy pool and spa water chemistry. The automatic feeding of these chemicals is performed using sensors, which continuously monitor the water circulating through the filter(s). Each of the sensors is associated with a chemical it is monitoring and feeding. These sensors, their connectors, and the feeder power cords, if present, are color coded. The **YELLOW** sensor is associated with the **pH** control channel which feeds an Acid or a Base (sometimes called caustic or alkaline) chemical. The **BLUE** sensor is associated with the feed of **Chlorine or Bromine** (sometimes called an oxidant or oxidizer). If these sensors or chemical feed pumps are not plugged into to the proper connections, or are connected to opposite devices, the uncontrolled feeding of one or both chemicals can occur. Uncontrolled or improper feeding of these two chemicals can cause serious injury or death to swimmers in the pool area from the formation of chlorine gas. Use extreme caution when connecting chemical feeders and sensors.

Mounting the System5F - Chapter 1

The Strantrol® System5F should be mounted to the wall. Make sure that the System5F is mounted in a location that is easily accessible, (Fig 1.1) free from chemical fumes and excessive heat, isolated from electrical interference, and powered by a power source protected by a ground fault interrupter. The System5F enclosure is weather resistant, but if mounting outdoors, locating the unit under a hood or overhang is recommended.

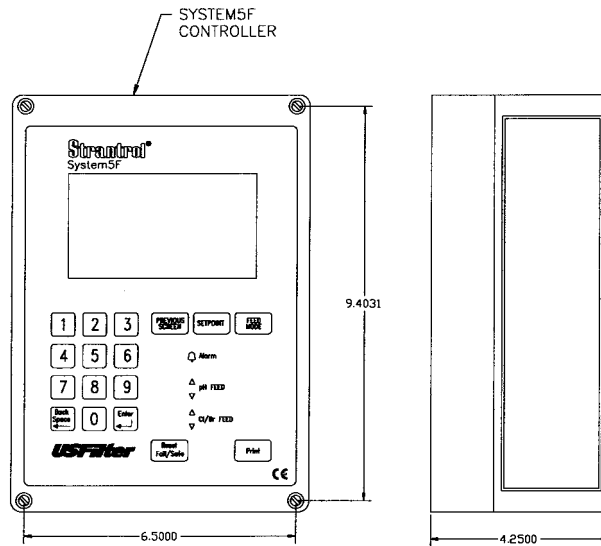

Fig 1.1

The flowcell can be mounted using two different techniques:

- Mount the flowcell next to the controller and run tubing from the flowcell to the sampling point (after filter, before heater) and discharge (before recirculation pump) of the recirculation system. (Fig 1.2)

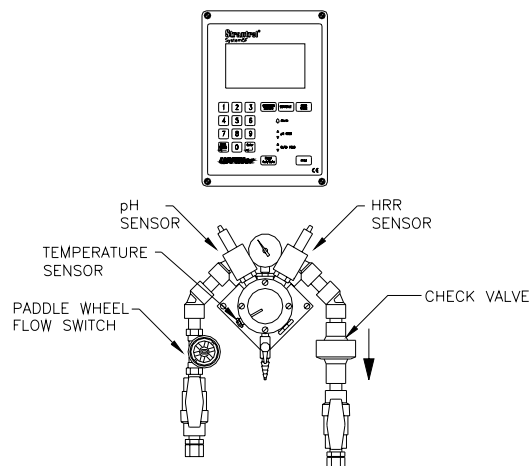

Fig 1.2

Technical Guide

- Mount the flowcell next to the sampling point (after filter, before heater) of the recirculation system and run wires to the System5F using a Signal Transmitter (refer to Signal Transmitter). (Fig 1.3)

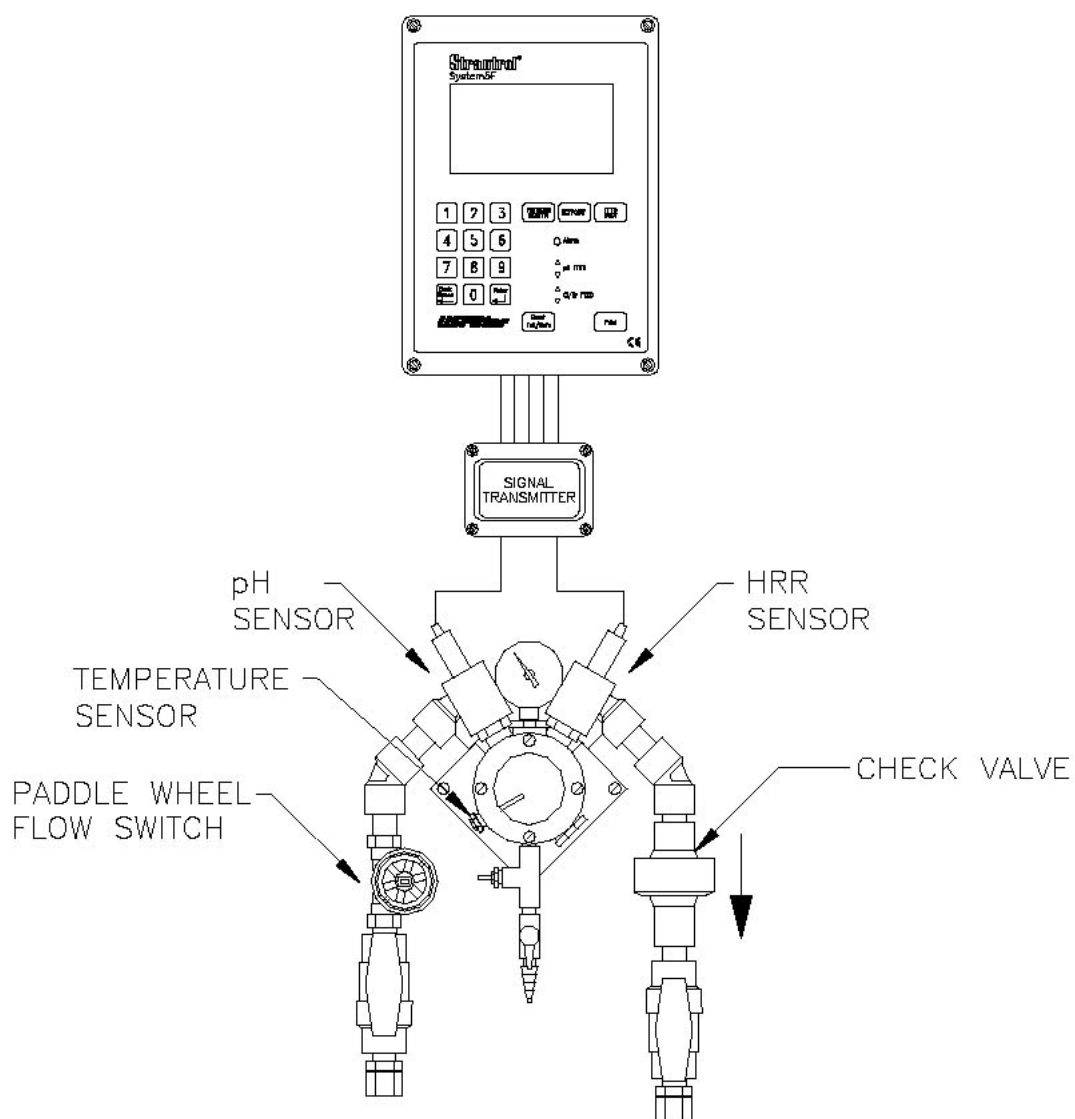
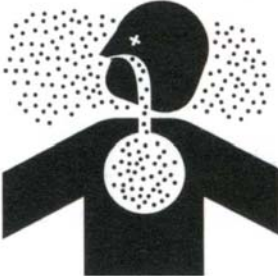

Fig 1.3

Plumbing Flowcell - Chapter 2

Assembling the flowcell

- First, wrap each fitting three times around clockwise with the Teflon[®] tape provided.
- Install ½" ball valves to allow isolation of the sample lines.
- Once you have finished assembling the flowcell, close the valves.
- Install the Paddlewheel Flow Switch in the sample stream. Make sure you only wrap the male fitting three times with Teflon[®] tape so as not to risk breaking the female fitting on the Paddlewheel Flow Switch. (Fig 2.1)

	<p>WARNING</p> <p>NEVER OVERRIDE SAMPLE FLOW SWITCH</p> <p>Uncontrolled feeding of chemicals can result in injury or death.</p> <p>Sample flow switch is a critical safety device which prevents uncontrolled chemical feed.</p> <p>Follow instructions carefully.</p>	<p>Flow switches are provided with all Strantrol controllers and are an integral safety device to prevent the uncontrolled feed of chemicals, which could cause personal injury or death. The flow switch should NEVER be bypassed, even temporarily, as this critical safety device will not be available to protect the swimmers.</p>
---	--	--

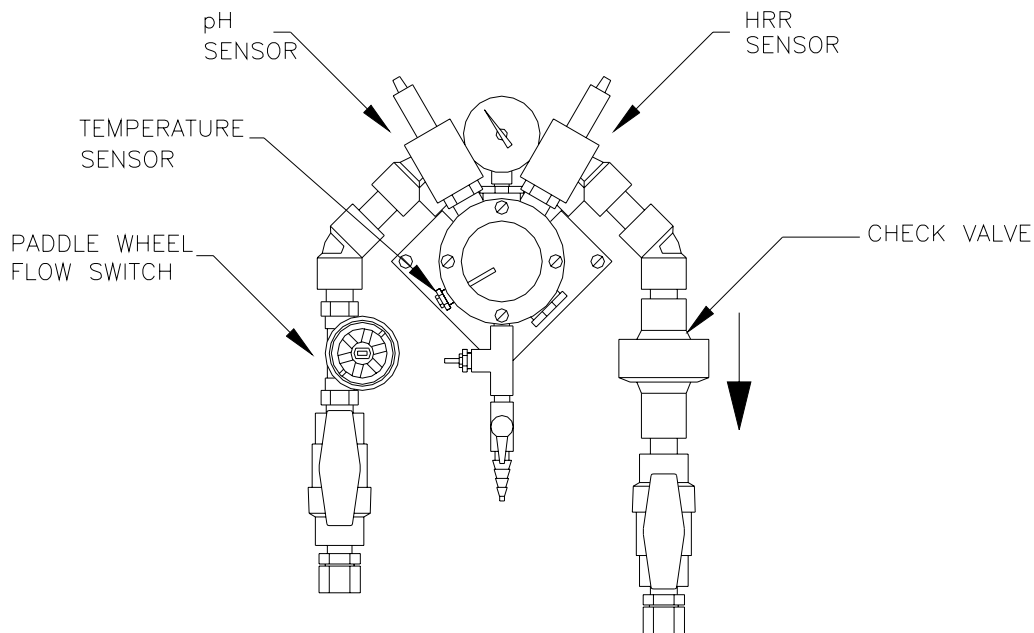



Fig 2.1

Plumbing the flowcell

- Half-inch tubing is recommended for sample stream pickup and return. We have included two connector fittings with the flowcell if needed.
- For the sampling point of the flowcell, tap downstream (after) of filter and upstream (before) of heater and chemical injection points.
- For the discharge point of the flowcell, tap upstream (before) of recirculation pump. (Fig 2.2)
- Remove the cap to the pH and HRR sensors, clean tips with a toothbrush and dish soap and then a light acid.
- Screw pH, HRR and Temperature sensors into flowcell. (Fig 2.1)



WARNING

ALWAYS USE ANTI-SIPHON DEVICES

Uncontrolled feeding of chemicals can result in injury or death.

Anti-siphon devices must be installed to prevent uncontrolled chemical feed.

Follow instructions carefully.

If a vacuum is created in the water circulation line and no anti-siphon device is installed on the chemical feeders, potentially hazardous concentrations of chemicals can be drawn into the pool or spa. Always use injection check valves and anti-siphon valves in the chemical feed lines to prevent this situation from occurring.

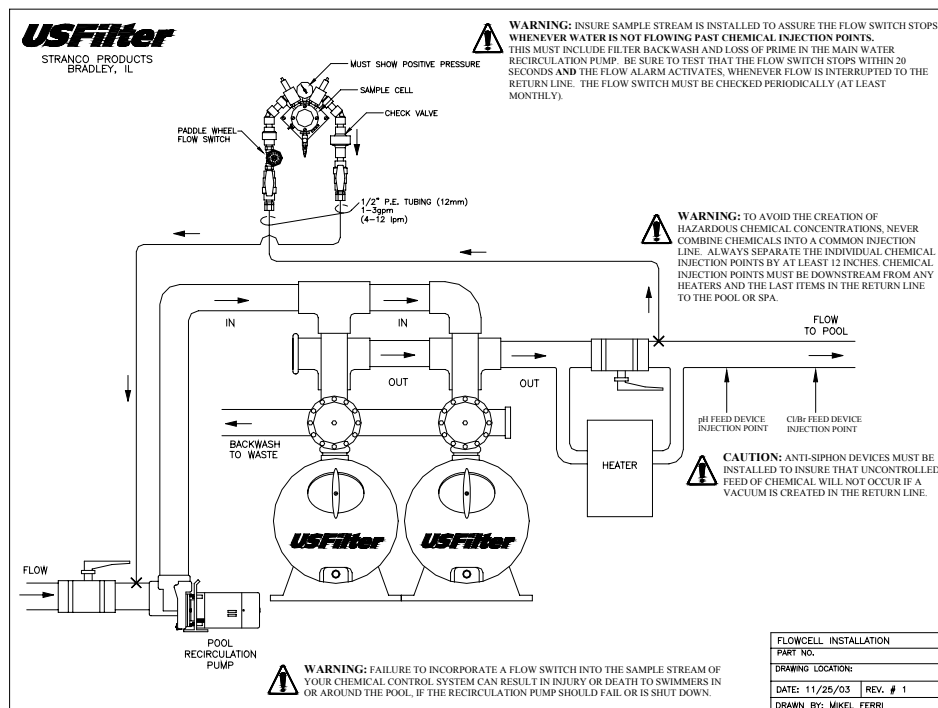
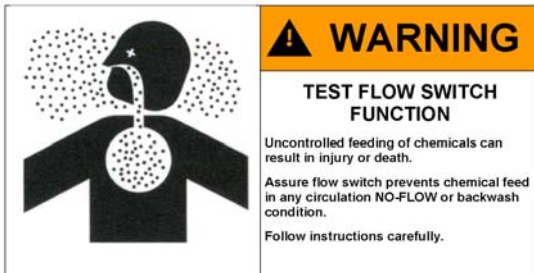

Fig 2.2

Checking the Flowcell

- Open the sample stream valves and check for leaks.
- Make sure the compound pressure gauge is showing a positive and steady pressure.
- Adjust the valves or relocate point at which the sample stream is connected to the recirculation system to ensure positive and steady pressure.
- Allow the sensors to rinse in the sample flowcell while you do the wiring.
- Open wet-test valve and make sure that it generates a vigorous stream.



If flow switch does not stop and remain stopped during backwash, no-flow, or very low flow conditions, the controller cannot prevent the uncontrolled feed of chemicals, which could cause personal injury or death.

Testing of the flow switch installation is essential to assure the flow switch stops, remains stopped, and controller shows "NO-FLOW ALARM" within 20 seconds, whenever filter is in backwash or circulation flow stops. If the flow switch does not stop completely, plumbing corrections or the installation of additional safeguards will be necessary to avoid uncontrolled chemical feed.

System Startup - Chapter 3

System5F Board Types

This page describes connections that your Strantrol representative needs to make in order for your System5F to function. Connections are presented in order of board type (or location):

Key	Description
4	Modem Board (for Serial/Output connections) (Fig 3.1)
3	Output Board(4-20 mA) (Fig 3.1) (Optional)
2	Input Board (Fig 3.1)
1	CPU Board (Fig 3.1)

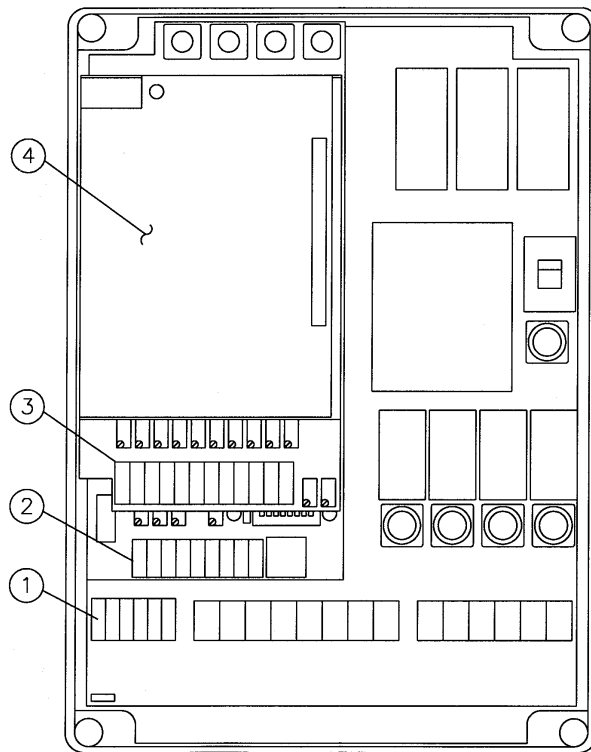

Fig 3.1

Running Power to System5F

- Open System5F and place lid to the left, lining up the right two holes of the lid with the left two holes of the base. (Fig 3.3)

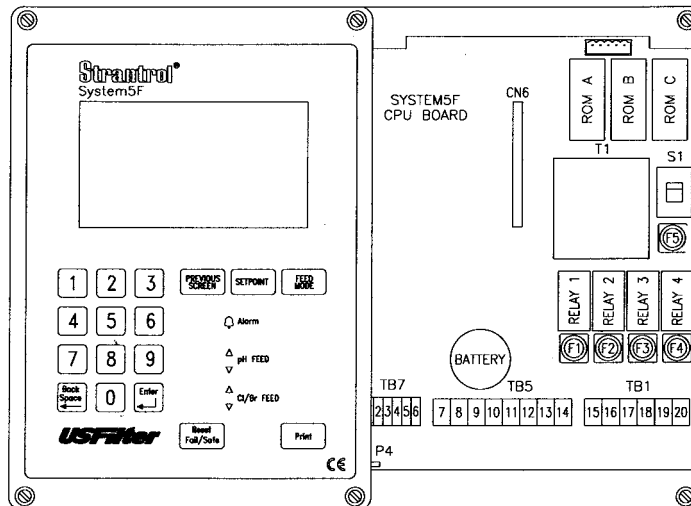



Fig 3.3

- If you are planning to use pigtails for the power, be sure to use NEMA 4X cord grips and plugs for unused holes. In addition, you must install warning labels on the pigtails. You may obtain these warning labels from Stranco Customer Service Department.
- Before wiring System5F, locate and check the “S1” switch for the right type of line voltage. (Fig 3.4) (Refer to page Chapter 3-5)



⚠ WARNING

ELECTRICAL SURGES CAN DAMAGE YOUR CONTROLLER

A damaged controller could feed chemicals in an uncontrolled manner.

Uncontrolled feeding of chemicals can result in injury or death.

If you suspect your controller is not operating properly, disconnect it from control of chemical feed.

Strantrol controllers, like all modern electronic devices can be damaged by severe electrical spikes and surges (think ‘lightning’). Every effort has been made to harden your Strantrol controller against such surges, but even that is not a guarantee that surge damage will not occur. If surge damage occurs, chemicals could be prevented from being fed to your pool or spa, continuously with no safety controls. If you inspect your Strantrol after a possibly damaging power surge (thunderstorm or power outage) and suspect the controller is not operating properly, disconnect the chemical feeders at once, and contact your Strantrol dealer for service.

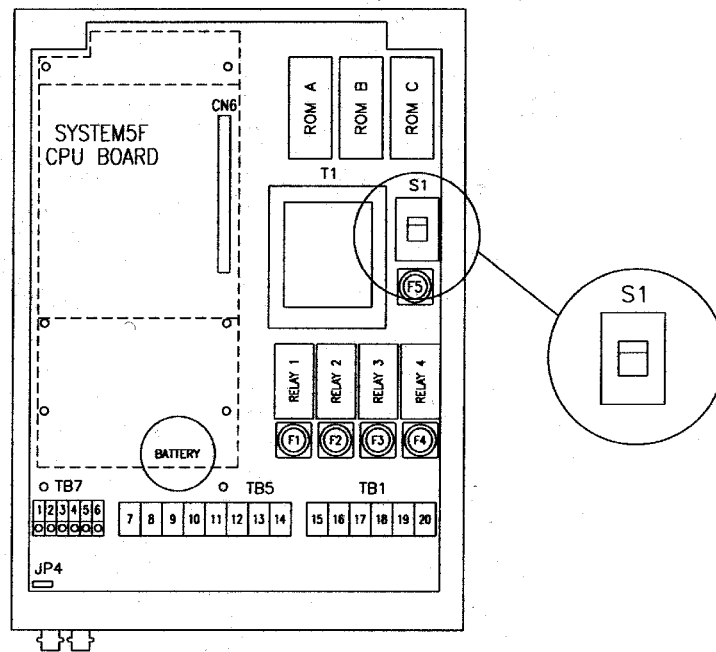

CPU PCB
IN ENCLOSURE

Fig 3.4

Locate Terminal labeled “TB5”.

- Run 120VAC, 60Hz, 15 AMP surge protected Line (Black) to terminal labeled “Line”. (Both “Line” terminals are connected.)
- Run Ground (Green) to terminal labeled “Ground”. (All three “Ground” terminals are connected.)
- Run Neutral (White) to terminal labeled “Neutral”. (All three “Neutral” terminals are connected.) (Fig 3.5)

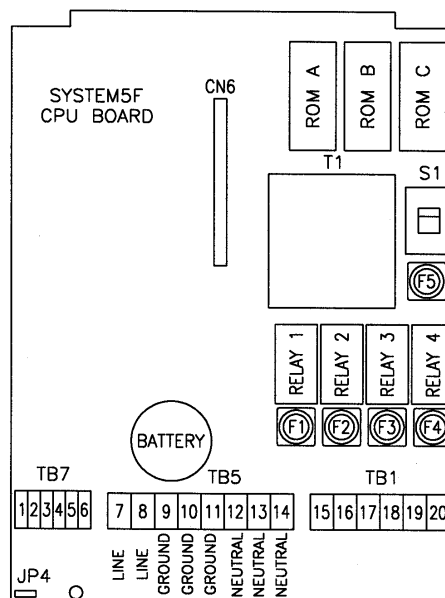

Fig 3.5

CPU Board Connections

Terminal	Description	Comments/Notes
TB7	1	Connects to face panel board terminal 1 (RS422 A)
	2	Connects to face panel board terminal 2 (RS422B)
	3	Connects to face panel board terminal 3 (RS422 Y)
	4	Connects to face panel board terminal 4 (RS422 Z)
	5	Connects to face panel board terminal 5 (RS422 V+)
	6	Connects to face panel board terminal 6 (RS422 GND)
TB5	7	AC Line (Main) (Black)
	8	AC Line
	9	Earth Ground (Green)
	10	Earth Ground
	11	Earth Ground
	12	AC Neutral (White)
	13	AC Neutral
	14	AC Neutral

TB7 provides wiring positions for connection to the user interface. Terminals 1 through 6 should be connected to TB1 on the user interface in the same order.

(This cable may be extended up to 4000 feet by using the remote interface kit.)

One line terminal is used for power in. 120VAC, 60Hz, 15 AMP surge protected

Used as Main Power, Earth, and Neutral connections.

NEVER connect controller power neutral to pump power neutral.

Warranty will be voided!



If the chemical feeders are connected to a wall outlet, the safety devices integral to your Strantrol controller, and to the safe feeding of chemicals, will be bypassed. It is very important that the chemical feeders are connected to the controller and never to a wall outlet. If the chemical feeders are connected to a wall outlet and feeding continuously, when the flow of water to the pool stops due to filter backwash, the circulation pump losing prime or other causes, potentially hazardous concentrations of chemicals can be fed into pool or spa.

TB1		There are two common terminals on TB1, terminals 16 & 19. Each one is a common for two of the four dry-contact relays. The other four terminals (15,17,18, and 20) on TB1, are the remaining output contacts for those relays.	
	15	Relay Output 1	Switched AC LOAD from Relay #1 (default configuration is pH control)
	 <p>WARNING ONLY CONNECT A pH FEEDER TO THIS OUTLET. Connecting a Chlorine/Bromine feeder to this outlet can cause chemical interactions that may cause personal injury or death. Insure feeders are connected properly to avoid hazardous chemical feed conditions. Never connect Chlorine/Bromine feeder to this connector. Strantrol pH Sensors are color coded as YELLOW.</p> <p>DO NOT REMOVE THIS LABEL</p>		<p>Oxidizers (Chlorine or Bromine), acids (Muratic, Carbon Dioxide, CO2) and caustics (Sodium Hydroxide, Caustic Soda, Soda Ash) are common chemicals used to automatically maintain safe and healthy pool and spa water chemistry. The automatic feeding of these chemicals is performed using sensors, which continuously monitor the water circulating through the filter(s). Each of the sensors is associated with a chemical it is monitoring and feeding. These sensors, their connectors, and the feeder power cords, if present, are color coded. The YELLOW sensor is associated with the pH control channel which feeds an Acid or a Base (sometimes called caustic or alkaline) chemical. If this sensor or chemical feed pumps are not plugged into the proper connections, or are connected to opposite devices, the uncontrolled feeding of one or both chemicals can occur. Uncontrolled or improper feeding of these two chemicals can cause serious injury or death to swimmers in the pool area from the formation of chlorine gas. Use extreme caution when connecting chemical feeders and sensors.</p>
	16	Common AC Power for Relay Output 1 & 2	LINE Power to Relay 1 & 2 (MAINS) which must be interlocked with main water recirculation pump control relay (motor starter aux. contact) to disable chemical feed when main recirculation pump is disabled.
	17	Relay Output 2	Switched AC LOAD from Relay # 2 (default configuration is Sensor Wash)
18	Relay Output 3	Switched AC LOAD from Relay # 3 (default configuration is Chlorine/Bromine)	

<p>TB1</p>		<p>Oxidizers (Chlorine or Bromine), acids (Muratic, Carbon Dioxide, CO₂) and caustics (Sodium Hydroxide, Caustic Soda, Soda Ash) are common chemicals used to automatically maintain safe and healthy pool and spa water chemistry. The automatic feeding of these chemicals is performed using sensors, which continuously monitor the water circulating through the filter(s). Each of the sensors is associated with a chemical it is monitoring and feeding. These sensors, their connectors, and the feeder power cords, if present, are color coded. The BLUE sensor is associated with the feed of Chlorine or Bromine (sometimes called an oxidant or oxidizer). If these sensors or chemical feed pumps are not plugged into to the proper connections, or are connected to opposite devices, the uncontrolled feeding of one or both chemicals can occur. Uncontrolled or improper feeding of these two chemicals can cause serious injury or death to swimmers in the pool area from the formation of chlorine gas. Use extreme caution when connecting chemical feeders and sensors.</p>
<p>19</p>	<p>Common AC Power for Relay Output 3 & 4</p>	<p>LINE Power to Relay 3 & 4 (MAINS) which must be interlocked with main water recirculation pump control relay (motor starter aux. contact) to disable chemical feed when main recirculation pump is disabled.</p>
<p>20</p>	<p>Relay Output 4</p>	<p>Switched AC LOAD from Relay # 4(default configuration is an Alarm Relay)</p>

CPU Board Connections

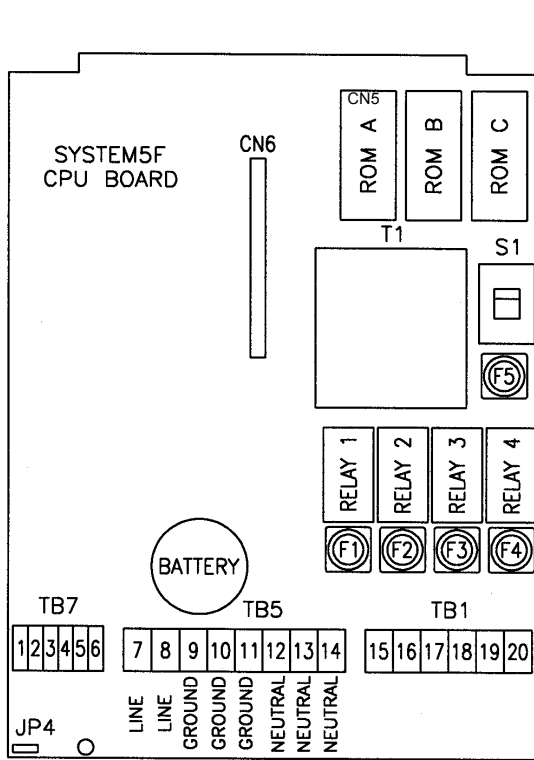

S1-Line Voltage Selector Switch. This switch is factory-set for either 115 or 230 volts.

CPU BOARD FUSE DESCRIPTIONS	
Terminal	Description
F1	3 amp Slo Blo fuse for Relay Output 1
F2	1 amp Slo Blo fuse for Relay Output 2
F3	3 amp Slo Blo fuse for Relay Output 3
F4	1 amp Slo Blo fuse for Relay Output 4
F5	Internal 3/4 amp Fuse for Strantrol Power

1 amp and 3 amp fuses needed for CSA, UL, and CE approvals

Fig 3.6

JP4 is the battery switch. Place jumper to the two right most pins to turn the battery ON. Typical life of the battery is 5 years.

Wiring Devices to Relays in the System5F

WARNING!

Controller power and feed device power must be separated. This setup reduces noise inside the controller and eliminates controller damage due to transient spikes from the pumps.

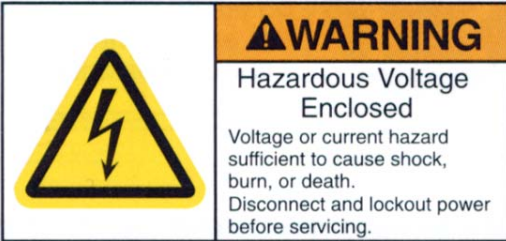

Line voltage (120/240VAC) can be present inside the Stranrol controller and caution should be used to prevent electrical shock, burns or electrocution. Be sure electric power is disconnected before opening the cover of any Stranrol. Follow all local safety policies, procedures and electrical codes, to prevent injury from electrical hazards, before opening the cover of this controller. If you are not trained and comfortable performing work on electrical equipment, contact a licensed electrician to perform the work.



If the chemical feeders are connected to a wall outlet, the safety devices integral to your Stranrol controller, and to the safe feeding of chemicals, will be bypassed. It is very important that the chemical feeders are connected to the controller and never to a wall outlet. If the chemical feeders are connected to a wall outlet and feeding continuously, when the flow of water to the pool stops due to filter backwash, the circulation pump losing prime or other causes, potentially hazardous concentrations of chemicals can be fed into pool or spa.

NEVER connect controller power neutral to feed device power neutral or **WARRANTY WILL BE VOID!**

- Relays 1 through 4 are already configured for specific functions but can be reconfigured for your application.

Relay 1	pH Feed Down
Relay 2	Sensor Wash
Relay 3	Chlorine Feed
Relay 4	Audible or Visual Alarm

- Other relay functions are below.

Control Action	Factory Default
pH Feed - Down	Relay 1
pH Feed - Up	
Sensor Wash	Relay 2
Chlorine/Bromine	Relay 3
Alarm	Relay 4
Dechlorination	
Superchlorination	
Heater	
Chlorine/Bromine Boost System	
Ozone	
The relays can be interchanged in any order, including multiple relays controlling the same function.	
Note: If two relays control the same function, they will trigger at the same setpoint.	

- Locate Terminal labeled “TB1” in the System5F. (Fig. 3.7)
- Connect device line to terminal labeled “N.O.#” (the # corresponds to the Relay #).

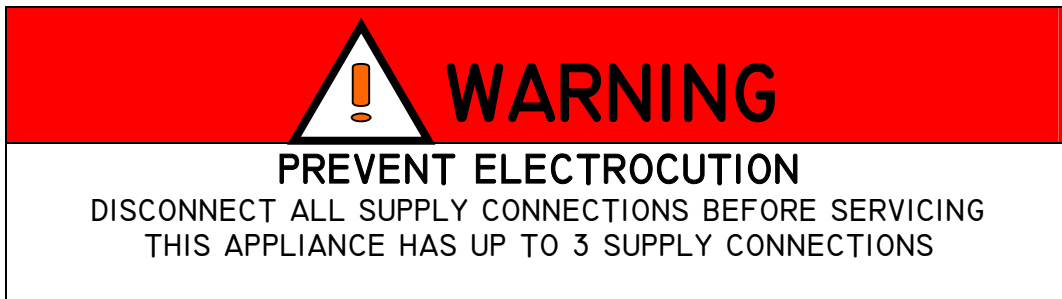

CAUTION: FOR CHANGE OF OPERATING VOLTAGE, REFER TO AUTHORIZED SERVICE PERSON.

ATTENTION: POUR ADAPTER L'APPAREIL À LA TENSION D'ALIMENTATION, COMMUNIQUER AVEC UN TECHNICIEN AUTORISÉ.

CAUTION: THIS UNIT MAY HAVE UP TO 3 POWER SUPPLY CONNECTIONS. DISCONNECT ALL POWER SUPPLY CONNECTIONS BEFORE SERVICING.

ATTENTION: CET APPAREIL REÇOIT PLUSIEURS ALIMENTATIONS. LE DÉBRANCHMENT DES CORDONS NE SUFFIT PAS NÉCESSAIREMENT À LE METTRE HORS TENSION.

RELAY WIRING MUST HAVE MINIMUM RATINGS OF 105°C, 600VAC, 14AWG AND HAVE INSULATION OF PVC TO COMPLY WITH THE MAXIMUM LOAD RATINGS FOR THIS EQUIPMENT. CONSULT YOUR NATIONAL OR LOCAL ELECTRICAL CODES FOR PROPER WIRING OF LESSER LOADS.

(Example: pH feed and Chlorine feed)

pH feed

- Locate Terminal labeled “N.O.1”. (TB1 #15)
- Run Line from pH feed device to “N.O.1”. (TB1 #15)
- Run Neutral to feed device neutral.
- Run Ground to feed device ground.



Oxidizers (Chlorine or Bromine), acids (Muratic, Carbon Dioxide, CO₂) and caustics (Sodium Hydroxide, Caustic Soda, Soda Ash) are common chemicals used to automatically maintain safe and healthy pool and spa water chemistry. The automatic feeding of these chemicals is performed using sensors, which continuously monitor the water circulating through the filter(s). Each of the sensors is associated with a chemical it is monitoring and feeding. These sensors, their connectors, and the feeder power cords, if present, are color coded. The **YELLOW** sensor is associated with the **pH** control channel which feeds an Acid or a Base (sometimes called caustic or alkaline) chemical. If these sensors or chemical feed pumps are not plugged into to the proper connections, or are connected to opposite devices, the uncontrolled feeding of one or both chemicals can occur. Uncontrolled or improper feeding of these two chemicals can cause serious injury or death to swimmers in the pool area from the formation of chlorine gas. Use extreme caution when connecting chemical feeders and sensors.

Chlorine Feed

- Locate Terminal labeled “N.O.3”. (TB1 #18)
- Run Line from chlorine device to “N.O.3”. (TB1 #18)
- Run Neutral to feed device neutral.
- Run Ground to feed device ground.

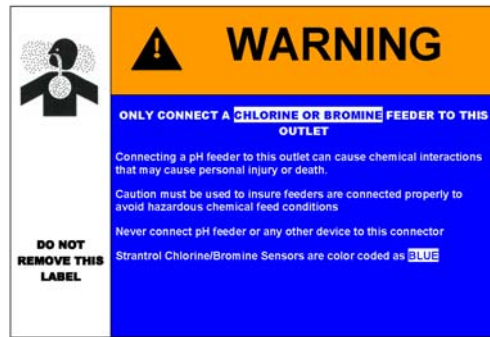

Oxidizers (Chlorine or Bromine), acids (Muratic, Carbon Dioxide, CO₂) and caustics (Sodium Hydroxide, Caustic Soda, Soda Ash) are common chemicals used to automatically maintain safe and healthy pool and spa water chemistry. The automatic feeding of these chemicals is performed using sensors, which continuously monitor the water circulating through the filter(s). Each of the sensors is associated with a chemical it is monitoring and feeding. These sensors, their connectors, and the feeder power cords, if present, are color coded. The **BLUE** sensor is associated with the feed of **Chlorine or Bromine** (sometimes called an oxidant or oxidizer). If these sensors or chemical feed pumps are not plugged into to the proper connections, or are connected to opposite devices, the uncontrolled feeding of one or both chemicals can occur. Uncontrolled or improper feeding of these two chemicals can cause serious injury or death to swimmers in the pool area from the formation of chlorine gas. Use extreme caution when connecting chemical feeders and sensors.

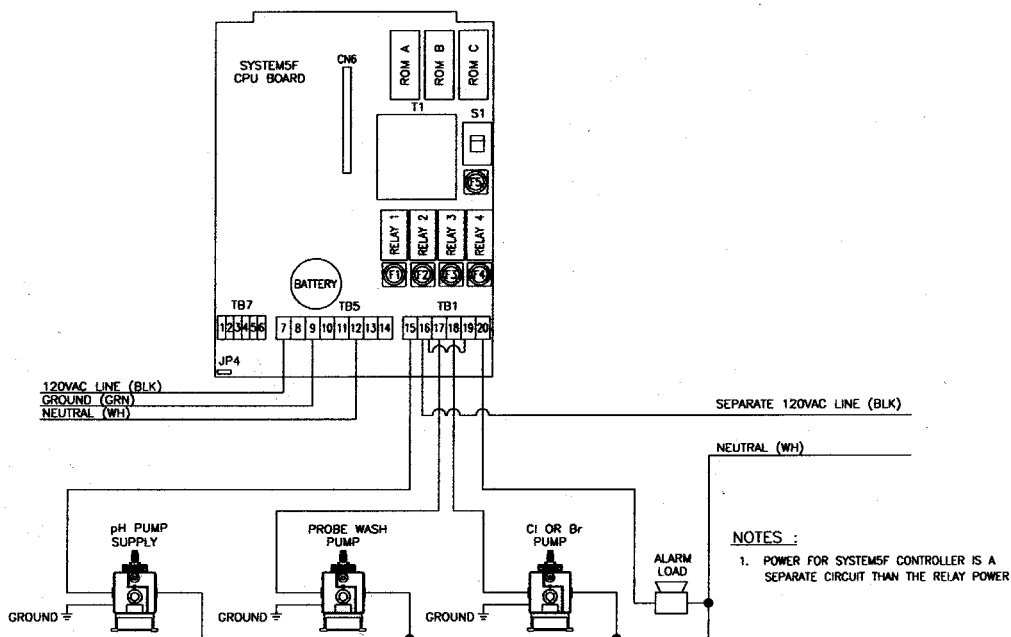

System5F Wiring

Technical Guide

Connecting Flowcell to System5F

pH, HRR and Temperature Sensors

- Plug pH sensor into the BNC jack on the left side of the System5F by twisting it a quarter of a turn to lock it.
- Plug HRR sensor into the BNC jack on the right side of the System5F by twisting it a quarter of a turn to lock it.
- Use a NEMA 4X cord grip to insert the Temperature Sensor cable into the System5F.
- Locate the Input Board. (Fig. 3.10)
- Locate “+Temp-” in the Terminal labeled TB1. (Fig. 3.11)
- Connect the white wire to TB1 position 3.
- Connect the black wire to TB1 position 4.

Water Ground

- Locate the Input Board. (Fig 3.10)
- Locate “W.Gnd” in the Terminal labeled TB1. (Fig 3.11)
- Locate the stainless steel grounding screw provided as a part of the Flowcell.
- Using a recommended 18 gauge wire.
- Connect the stainless steel grounding screw to “W.Gnd” in TB1 position 1.

Flow Switch

	<p>WARNING</p> <p>NEVER OVERRIDE SAMPLE FLOW SWITCH</p> <p>Uncontrolled feeding of chemicals can result in injury or death.</p> <p>Sample flow switch is a critical safety device which prevents uncontrolled chemical feed.</p> <p>Follow instructions carefully.</p>	<p>Flow switches are provided with all Strantrol controllers and are an integral safety device to prevent the uncontrolled feed of chemicals, which could cause personal injury or death. The flow switch should NEVER be bypassed, even temporarily, as this critical safety device will not be available to protect the swimmers.</p>
---	--	--

- Locate the Input Board (Fig 3.10)
- Locate “Flow”, “V+”, “V-” in the Terminal labeled TB1. (Fig. 3.11)
- Locate the Flow Switch from the flowcell.
- Connect the White wire to “Flow” in TB1 position 5.
- Connect the Red wire to “V+” in TB1 position 6.
- Connect the Black wire to “V-” in TB1 position 7.

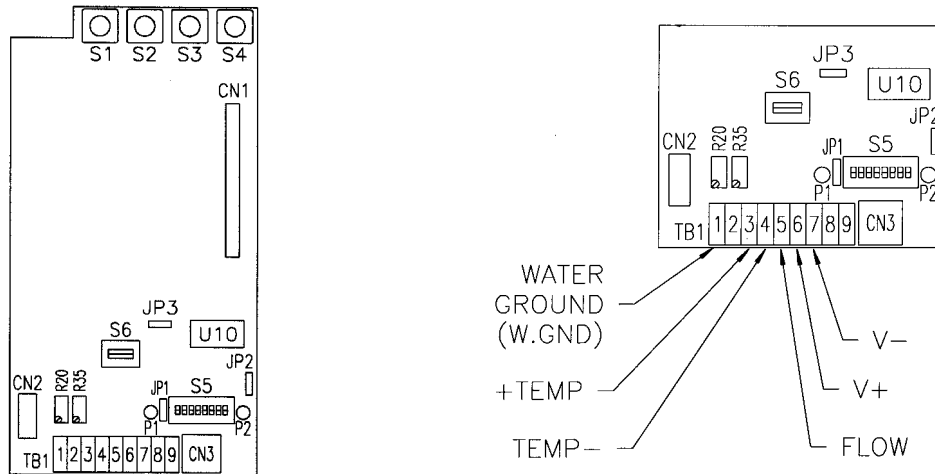

Fig. 3.10 & Fig. 3.11

	<p>WARNING</p> <p>TEST FLOW SWITCH FUNCTION</p> <p>Uncontrolled feeding of chemicals can result in injury or death.</p> <p>Assure flow switch prevents chemical feed in any circulation NO-FLOW or backwash condition.</p> <p>Follow instructions carefully.</p>	<p>If flow switch does not stop and remain stopped during backwash, no-flow, or very low flow conditions, the controller cannot prevent the uncontrolled feed of chemicals, which could cause personal injury or death.</p>
--	--	---

Optional: Signal Transmitter

- Locate Input Board (Fig. 3.10)
- Locate Switch labeled S6 just above TB1. (Fig. 3.11)
- S6 must be in the up position. (Fig. 3.12)
- Locate the Terminal labeled JP1 in the Signal Transmitter.
- Connect “Flow” on the Input Board to JP1 position 5.
- Connect “V+” on the Input Board to JP1 position 1.
- Connect “V-“ on the Input Board to JP1 position 2.
- Connect “1Pamp” on the Input Board to JP1 position 3.
- Connect “Pamp2” on the Input Board to JP1 position 4.

Technical Guide

System5F Input Board	Signal Transmitter
Flow (TB1 position 5)	JP1 position 5
V+ (TB1 position 6)	JP1 position 1
V- (TB1 position 7)	JP1 position 2
1Pamp (TB1 position 8)	JP1 position 3
Pamp2 (TB1 position 9)	JP1 position 4

- Connect the White wire from the Flow Switch to JP2 position 7 in the Signal Transmitter.
- Connect the Red wire from the Flow Switch to JP2 position 6 in the Signal Transmitter.
- Connect the Black wire from the Flow Switch to JP2 position 8 in the Signal Transmitter.
- Plug pH sensor into the BNC jack on the left side of the Signal Transmitter by twisting it a quarter of a turn to lock it.
- Plug HRR sensor into the BNC jack on the right side of the Signal Transmitter by twisting it a quarter of a turn to lock it.
- Connect the Temperature sensor to the terminals on the lid of the Signal Transmitter.
- Connect the terminals of the lid to the Temperature TB1 positions 3 & 4 on the Input Board.
- Make sure the polarity is correct.
- White in “+Temp” (TB1 position 3).
- Black in “Temp-” (TB1 position 4).
- The Signal Transmitter is just a junction box for the Temperature Sensor.

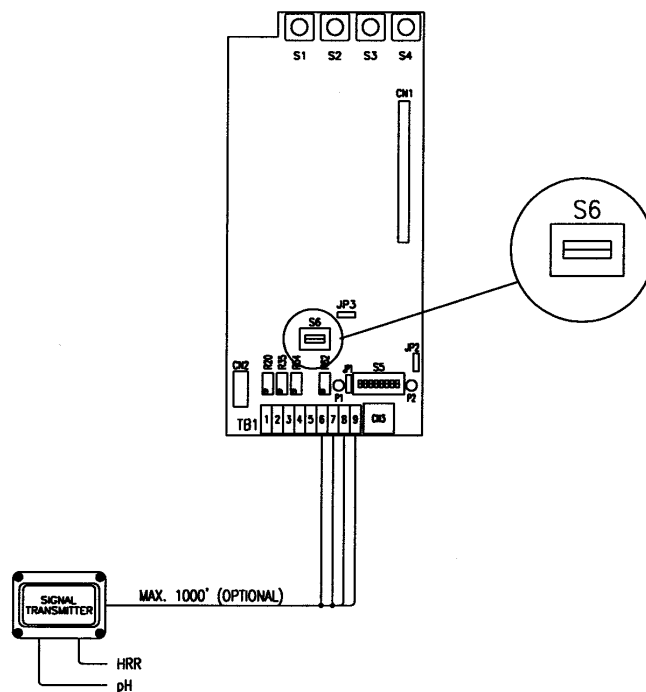

Fig 3.12

Input Board Connections

Input Board Terminal Descriptions (TB1) - Analog Input Connections		
Terminal/Description		Comments/Notes
1	Water Ground	The water ground MUST be connected to the water. This may be done by connecting wire between Terminal 1 and stainless screw provided in flowcell.
2	Chlorine reference voltage	4 channel unit only.
3	Temperature (+) signal	Connect from Temperature Probe (White)
4	Temperature (-) signal	Connect from Temperature Probe (Black)
5	Flow Input	Connect to white wire from flow switch.
6	+12VDC	Connect to red wire from flow switch.
7	DC Common	Connect to black wire from flow switch.
8	Transmitter Input #1	Isolated signal transmitter hook-up. Remote mounting up to 1000 ft.
9	Transmitter Input #2	



WARNING
NEVER OVERRIDE SAMPLE FLOW SWITCH
 Uncontrolled feeding of chemicals can result in injury or death.
 Sample flow switch is a critical safety device which prevents uncontrolled chemical feed.
 Follow instructions carefully.

Flow switches are provided with all Strantrol controllers and are an integral safety device to prevent the uncontrolled feed of chemicals, which could cause personal injury or death. The flow switch should **NEVER** be bypassed, even temporarily, as this critical safety device will not be available to protect the swimmers.

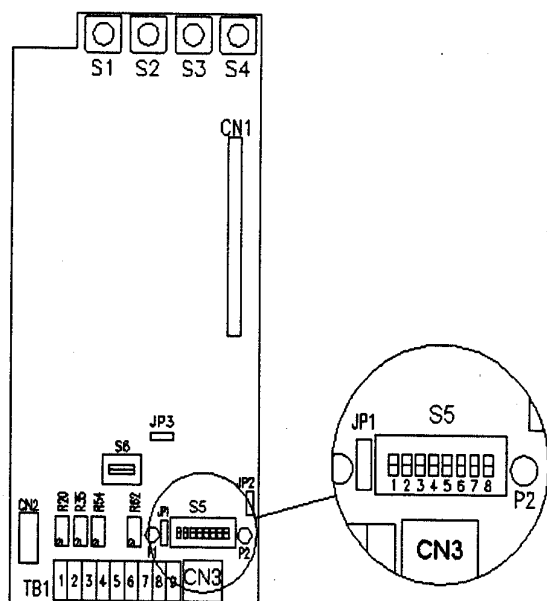

Fig 3.14

INPUT BOARD S5 POSITIONS / DESCRIPTIONS	
Position	Description
1	ON Removes ppm reading OFF Normal display
2	Not Used
3	European Date. ON=dd/mm/yy English Date. OFF=mm/dd/yy
4	Not Used
5	Direct / Modem selection OFF = Direct ON = Modem (or voice)
6	Voice Modem. ON = voice modem OFF = No voice modem
7	Factory Use Only
8	Factory Use Only

Input Board Connections

INPUT BOARD PUSH BUTTONS (MOMENTARY CONTACT)	
Switch #	Description
S1	Manual Override for Relay 1
S2	Manual Override for Relay 2
S3	Manual Override for Relay 3
S4	Manual Override for Relay 4
S1 through S4 will be used only by authorized personnel during installation.	

INPUT BOARD NOTES		
	Description	Comments/Notes
CN2	Connector for BNC inputs from pH/HRR sensors	See S6 below and use input terminal connections if using a signal transmitter.
S5	Main Dip Switch Bank	
S6	Determines whether the pH/HRR sensor inputs are from the BNC connector or from a remote signal transmitter.	Set this switch UP to use the signal transmitter input. Set this switch DOWN to use the BNC input.

Output Board 4-20 mA Connections

All output signals are 4-20 mA. Output connections are made to TB1.

Output signals may be for either:

- Control and/or
- Recording.

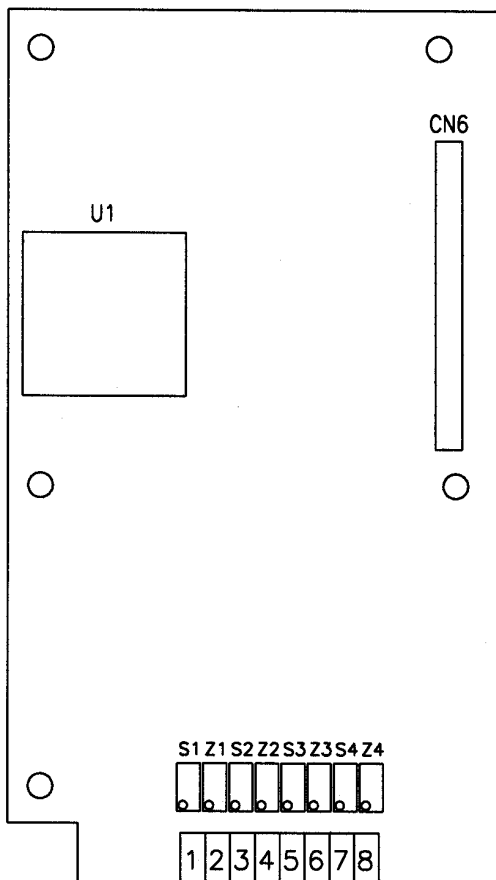

Fig 3.15

Output Board 4-20 mA Connections

4-20 mA OUTPUT BOARD TERMINAL DESCRIPTIONS		
TERMINAL	DESCRIPTION	DEFAULT VALUES
1	(+) 4-20 mA output signal for Channel #1 Recorder	pH 6.0 - 9.0
2	(-) 4-20 mA output signal for Channel #1 Recorder	
3	(+) 4-20 mA output signal for Channel #2 Recorder	HRR 0 -1000 mV
4	(-) 4-20 mA output signal for Channel #2 Recorder	
5	(+) 4-20 mA output signal for Channel #3 Recorder	ppm 0 - 20 ppm
6	(-) 4-20 mA output signal for Channel #3 Recorder	
7	(+) 4-20 mA output signal for Channel #4 Recorder	Temperature 60 - 100
8	(-) 4-20 mA output signal for Channel #4 Recorder	

Serial Input/Output Connections on the Modem Board

CN2 (phone) is the phone line connection for the modem.

CN3 (PC-Con) is the RS-232 direct connect port.

NOTICE: If you plan to use the Voice Modem (optional) with the System5F, ignore this page and the next page on Modem Board Connection.

COM SELECT switch allows a switch between remote access and direct access. Along with dipswitch #5 on input board.

Fig 3.16

For remote connection, CN2 is a standard RJ-11 phone connection. This connector utilizes remote communication outlet only. (Switch COM SELECT to phone (forward) and use CN2). Dipswitch #5 on input board to up position.

For direct computer connection, switch COM SELECT to PC-Con (toward back) and use CN3 (offset MMJ connector). Set dipswitch #5 to off position.

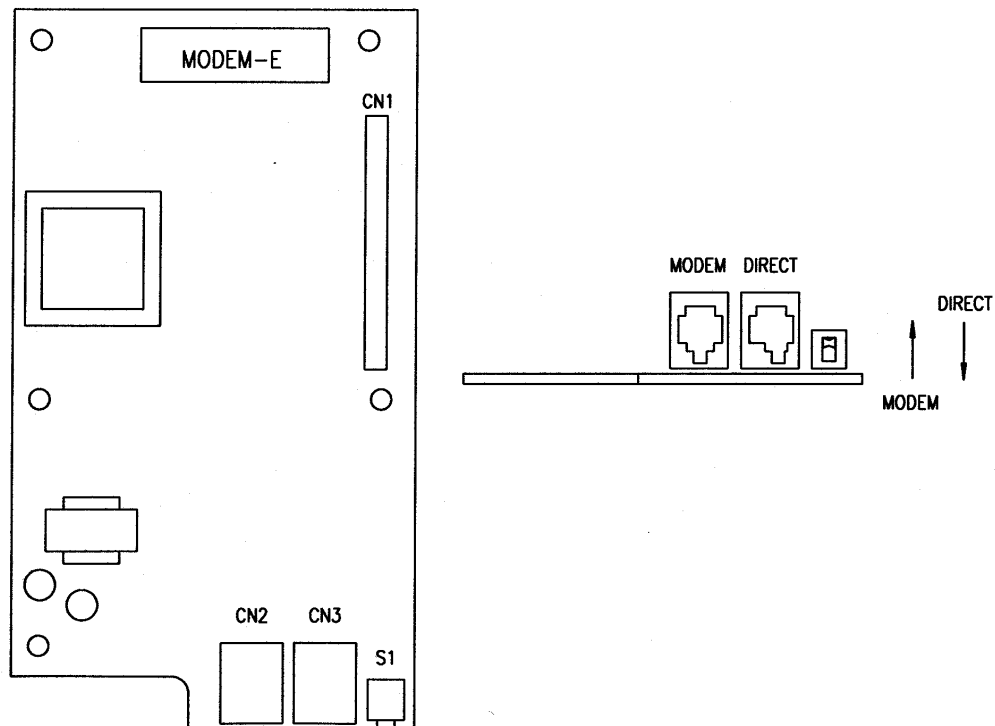

Fig 3.16

Printer Board Connections (Optional)

Printer Board Terminal Descriptions		
Terminal	Description	Color
1	Signal Ground	Black
2	Receive (no connection)	
3	Transmit	Red
4	Clear to Send	White
5	Ready to Send (no connection)	

Note: To connect to a printer other than supplied by USFilter Stranco Products, please consult your authorized USFilter Stranco Products representative.

Pin Connections Between System5F Terminal and Printer DB25 Pin Connector:

System6 Terminal	Printer 25 Pin
1	7
3	2
4	5

TAN PRINTER

System6 Terminal	Printer 25 Pin
1	7
3	3
4	11

**GRAY PRINTER
(OLD)**

Common Installation Errors

Review of Common Problems and Solutions

Before contacting the USFilter Stranco Products service staff with questions on your new installation, review the following common problems and solutions.

The most common installation error is an improperly connected water ground.

The **water ground** must be connected to the proper terminal in the controller and to the connector on the flowcell.

Feed devices will not start

The relays are dry contact. To activate a feed device, power must be provided to the relay contacts.

To provide 120 VAC to all four relays:

- Connect a jumper wire from the CPU board TB5 #7 or #8 (both are AC line) to TB1 #16 (Com 1,2). Connect another jumper from TB1 #16 to TB1 #19 (Com 3,4).

WARNING: This will bypass the interlocking protection and should only be done for troubleshooting purposes.

- Consult the wiring diagram for correct wiring. Fig 3.12

The HRR or pH Displays Fluctuate Rapidly

- Check the **water ground connection**, both in the controller and on the flowcell.
- Connect a signal generator and verify that the SG-700 ground lead is connected.
- Verify that the display matches the signal generator readings.
- Check BNC to input board connections.
- Check S6 input switch position.
Down (off) for BNC/sensor input,
Up (on) for preamp input.

The chlorine reading is WAIT.

If the pH changes more than .08 in one minute, the WAIT message is displayed in place of the ppm reading. It prevents standardization of the chlorine display until pH stabilizes. This wait time may be up to 30 seconds.

Menu Access

An Operator, Manager or Representative access code is required to perform procedures described in this chapter.

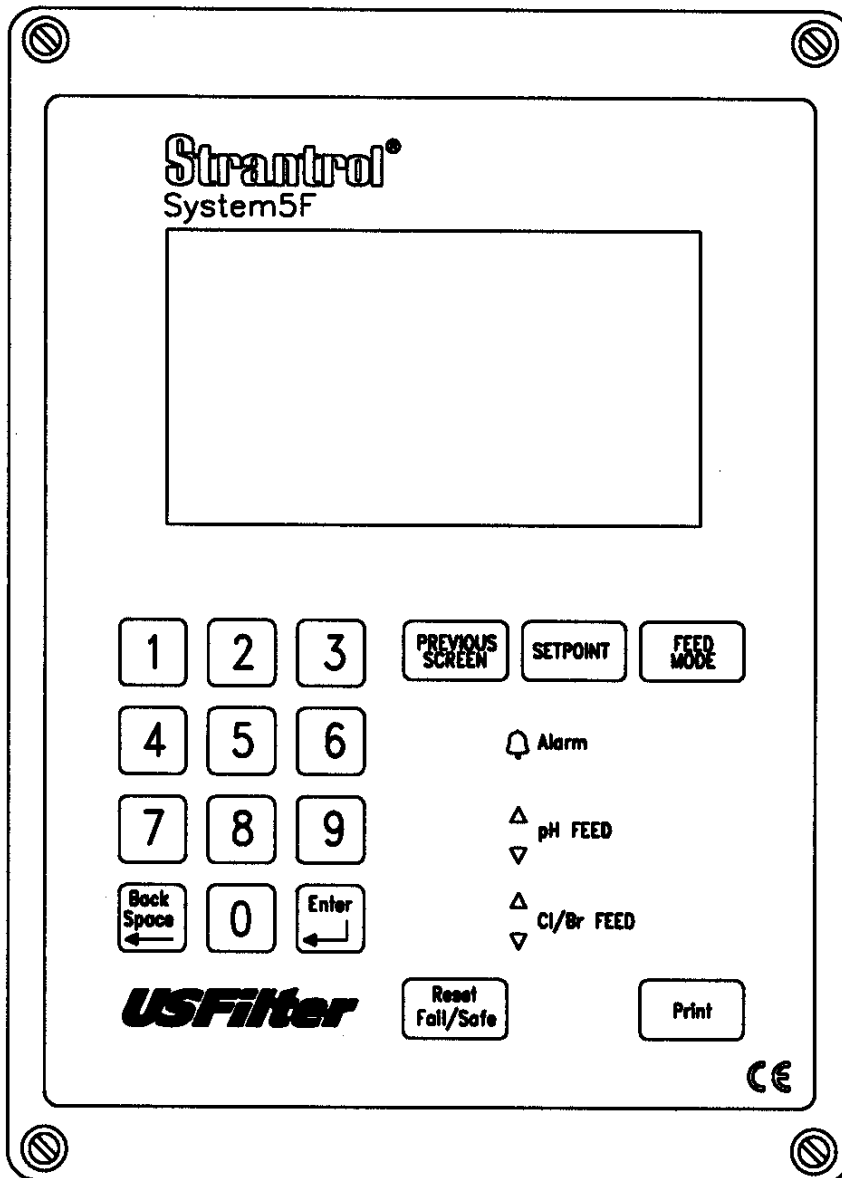

Fig 3.17

Quick Reference Guide - Functions & Access Levels

Functions - Listed by Level:			
	Representative Level	Manager Level	Operator Level
	Hardware Calibration Recorder Outputs Software Calibration Rep startup All Manager Level options All Operator Level options Control tuning	Alarm setup Sensor wash programming Superchlorination programming Current date programming Current time programming All Operator Level options	pH setpoint pH auto-off-manual pH calibration (standardize) HRR setpoint HRR auto-off-manual ppm setpoint ppm auto-off-manual ppm calibration
To Gain Access:			
	Representative Level	Manager Level	Operator Level
1	Press the <i>Enter</i> key to display the different viewing options.		
2	Press 9 to enter the Representative access code.	Press 2 to enter the Manager access code.	Press 1 to enter the Operator access code
3	Press the Numbered keys to enter in your access code.		
4	Menus have a two-minute time-out. If there is no activity on the control buttons for at least two minutes, the system exits the menu and reverts to the Display Level.		

Data Logging

Event

The System5F considers changes within its system as **events**. Examples of events would be:

- Relays opening and closing
- Alarm conditions
- Parameter changes

Event Buffer

Each time an **event** occurs, an entry is made in the event buffer.

When an event is stored it received a time stamp. You can, therefore, trace changes to the system to the time the event occurred.

The event buffer has room for 1000 entries. When the buffer fills up, the oldest entry is erased to make room for new entries.

The SVC program allows you to download the event buffer to a PC hard drive or a floppy diskette. If you download the event buffer before it fills up, you will have a PC-compatible record of the event history saved. In the meantime, the System5F will erase the oldest entries to make room for new ones.

How frequently you schedule your downloads depends on whether you want to save high resolution or low resolution storage information.

High/Low Resolution Logs

The System5F stores parameter readings at two resolutions simultaneously:

High Resolution, which stores minimum, maximum, average and sample values for the specified time frame.

Low Resolution, which stores minimum, maximum, average and sample values for the specified time frame.

	High Resolution	Low Resolution
The default time period stores values every:	6 minutes	2 hours
The minimum setting is:	1 minute	1 hour
The maximum setting is:	6 minutes (the default)	4 hours
When using the minimum setting, history is stored for:	9 hours	17 days
When using the maximum setting, history is stored for:	2 days - 6 hours	68 days
When using the default setting, history is stored for:	2 days - 6 hours	34 days

The amount of time that history is stored represents the maximum amount of time you can schedule downloads. For example, if your high resolution is set at the default, you must download high-resolution data every 2 days -6 hours. If you wait 2 days - 7 hours between downloads, System5F will erase the oldest information in the buffer in order to make room for the new information.

Control Logic & Functionality

System Startup

A system startup occurs after a power cycle or a system reset. During system startup the LCD displays the message "System Startup." An underscore moves along the bottom of the System Startup message.

Temperature Option

The temperature is displayed on the screen and is used in determining the LSI and the Ryznar index. The temperature default for this calculation, if temperature probe is not present, is 83°F.

Enabling the Temperature Control Option

To enable or disable the Temperature Option, enter the menu through the Representative Level. [Diagnostics] : [Hardware Calibration] : [Temperature] : 0 [enable] : 1 [disable].

Here is some useful information on the ranges and resolution of pH and HRR.

	pH Input	HRR Input	ppm Input High Scale
Range:	0.0 to 14.0 pH	0 mV to 1000 mV	0.0 to 6.0 ppm
Resolution:	0.01 pH	1 mV	0.1 ppm

Ozone Option

The purpose of the ozone option is to allow control of an ozonator.

The operation of the ozonator relay is basic. The relay is normally closed (i.e. the ozonator is "ON") under normal operation. When the System5F recognizes a high HRR alarm, the relay switches (in other words, the ozonator is "OFF").

Enabling the Ozone Option

1. Enter the menu system using the Representative access code.
2. Select [Rep Startup].
3. Select one of the four relays to operate the ozone. Selecting a relay for ozone enables ozone control on that relay.
4. Adjust HRR High Alarm parameter as needed.

Technical Guide

Parts and Supplies

You may order parts needed below from your local representative or by calling your local USFilter Stranco Products office and ask for Aquatic Customer Support.

If you need any other parts for your Strantrol System 5F, contact your local Strantrol representative or your nearest USFilter Stranco Products office.

Your nearest USFilter Stranco Products office is listed on the back of this manual.

Part Reference	Part Description	USFilter Stranco Part Number
Fuse F1 and F3	3 Amperes, 250 Volt	S403 Locally available
Fuse F2 and F4	1 Ampere, 250 Volt	S403 Locally available
Fuse F5	¾ Ampere, 250 Volt	S403 Locally available
Relays R1, R2, R3, and R4	5 Amperes, 280 Volt, solid state	7373002
Battery B1	Lithium, 3 Volt	1380005
Acid/Caustic Sensor Short Yellow	pH Sensor 32 inches	7040004
Acid/Caustic Sensor Long Yellow	pH Sensor 10 Feet	7040002
Chlorine/Bromine Sensor Short Blue	HRR Sensor 32 inches	7042002
Chlorine/Bromine Sensor Long Blue	HRR Sensor 10 Feet	7042003
Temperature Sensor	RTD, 100 ohm, 2 wire, w/Thermowell	7049011

Maintenance

Cleaning the Sensors

The System5F requires no maintenance other than a periodic calibration check and sensor cleaning.

1. Isolate the Flowcell, then remove the sensors.

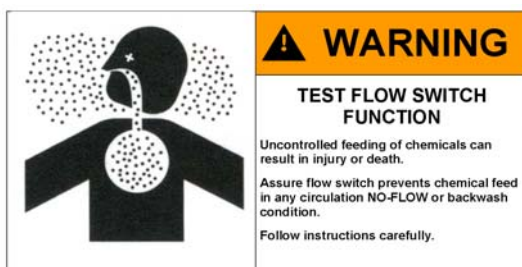

If flow switch does not stop and remain stopped during backwash, no-flow, or very low flow conditions, the controller cannot prevent the uncontrolled feed of chemicals, which could cause personal injury or death.

Testing of the flow switch installation is essential to assure the flow switch stops, remains stopped, and controller shows "NO-FLOW ALARM" within 20 seconds, whenever filter is in backwash or circulation flow stops. If the flow switch does not stop completely, plumbing corrections or the installation of additional safeguards will be necessary to avoid uncontrolled chemical feed.

2. Clean the tips with HRR Cleaning Solution and a toothbrush.
3. Check Teflon® sealing tape on threads and reinstall sensor.
4. Open valves and let sensors rinse 10 to 15 minutes in sample stream water before making any adjustments.

NOTE: If the sample stream is shut down for more than a short time (particularly in freezing temperatures), remove the sensors from the flowcell and unplug the System5F. Store the sensors in a heated, secure area, with the sensor caps in place or with the tips immersed in any small container of water to prevent them from drying out.

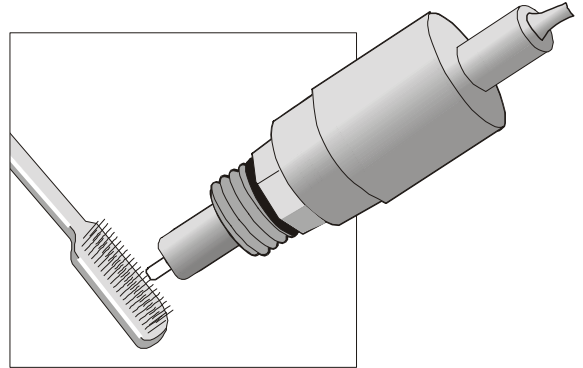

Control Tuning - Chapter 4

pH Control Options

	pH Feed-down	pH Feed-up
	Feed-down means that when chemical is fed, the pH lowers.	Feed-up means that when chemical is fed, the pH rises.
	Hook-up the pH feed device to appropriate relay as shown in the wiring diagrams.	Hook-up the pH feed device to appropriate relay as shown in the wiring diagrams. (Reprogram Relay)
1	Enter the menu system using a Manager or Representative access code.	
2	Select [pH SETUP]:[pH feeddn or feedup Mode].	
3	Select whether the pH control is on/off[0] or proportional[1].	
	With on/off control (and pH feed-down), whenever the pH is above the setpoint, the pH feed device will be [on] until setpoint is reached.	With on/off control (and pH feed-up), whenever the pH is below the setpoint, the pH feed device will be [on] until setpoint is reached.
4	Select [pH prop span](proportional span).	
5	If you selected on/off control, ignore this step.	
	If you selected proportional mode, select the control proportional span. The proportional span defines the "window" of control for the pH chemicals.	
	<u>Settings</u> Setpoint 7.5 Proportional span .5 <u>Input pH Value</u> <u>Feed device Duty Cycle</u> 8.0 100% 7.8 60% 7.5 0%	<u>Settings</u> Setpoint 7.5 Proportional span .5 <u>Input pH Value</u> <u>Feed device Duty Cycle</u> 7.0 100% 7.2 60% 7.5 0%
6	Select [pH feed down F/S].	Select [pH feed down F/S].
7	The fail/safe alarm sets a feed time-out value. If the feed device operates for this period of time without reaching setpoint, a fail/safe alarm is recognized and the control relay is disabled (locked out).	

Chlorine or Bromine Control Options

Hook-up the chlorine (or bromine) feed device to the appropriate relay. Action of chlorine feed device will be controlled from an HRR sensor.

Software Programming for the Chlorine (or Bromine) Relay (relay 3).																	
1	Enter menu system using Manager or Representative access codes.																
2	Select [HRR SETUP: HRR/Cl ppm cntrl].																
3	Select [HRR]. Select [ppm].																
4	Select [HRR (Cl/Br) Feed Mode].																
5	Select whether the chlorine control is on/off [0] or proportional [1].																
	NOTE: With on/off control, whenever the chlorine is below the set point, the chlorine feed device will be [on] until setpoint is reached.																
6	Select [HRR F/S Alarm].																
7	The fail/safe alarm sets a feed time-out value. If the feed device operates for this period of time without reaching set point, a fail/safe alarm is recognized and the control relay is disabled (locked out).																
8	Select [HRR prop span].																
9	If proportional mode was selected (in step #6), select the control proportional span. If on/off was selected, ignore this step.																
10	NOTE: The proportional span defines the "window" of control for the System5F.																
	<table border="0"> <tr> <td colspan="2"><u>HRR Settings</u></td> </tr> <tr> <td>Set point =</td> <td>750</td> </tr> <tr> <td>Proportional span =</td> <td>20</td> </tr> <tr> <td colspan="2"> </td> </tr> <tr> <td><u>Input pH Value</u></td> <td><u>Feed device Duty Cycle</u></td> </tr> <tr> <td>730</td> <td>100%</td> </tr> <tr> <td>740</td> <td>50%</td> </tr> <tr> <td>750</td> <td>0%</td> </tr> </table>	<u>HRR Settings</u>		Set point =	750	Proportional span =	20	 		<u>Input pH Value</u>	<u>Feed device Duty Cycle</u>	730	100%	740	50%	750	0%
<u>HRR Settings</u>																	
Set point =	750																
Proportional span =	20																
<u>Input pH Value</u>	<u>Feed device Duty Cycle</u>																
730	100%																
740	50%																
750	0%																

Alarm Warning Bands

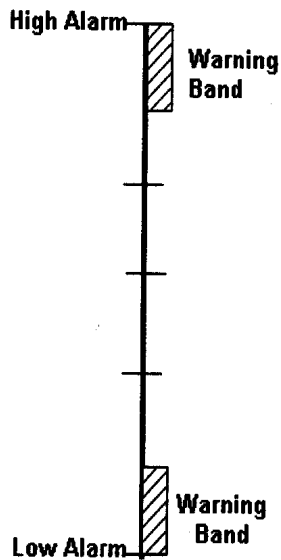

Figure 2.1

Alarm **warning bands** and **warning time counters** are exclusive features of the Strantrol product line. A warning band serves as a time delay for an alarm and allows the controller to anticipate the trend of the reading as it nears the alarm setpoint. As the values approach the alarm setpoint, the warning time needed to recognize and respond to an alarm condition is triggered.

This prevents an alarm from tripping due to a short term out-of-range condition. The System5F uses alarm warning bands and warning times to:

Ignore transient conditions, which could create unnecessary alarms.

Extend the "range of concern" beyond the alarm setpoint:

Values beginning to move toward a high (or low) alarm are allowed a degree of warning time.

Values closely approaching a high (or low) alarm are allowed less warning time than values further away from the alarm point.

Values that exceed an alarm point will trigger an immediate alarm (the warning time become 0).

Availability

The System5F is shipped from the factory with all warning bands disabled (i.e., set to 0.0 or 0 mV).

Rules/Logic

A counter for the warning time activates whenever a value falls within a warning band range.	
If the value:	Then ... :
Stays within the warning band long enough to exceed the warning time, ...	The alarm is sounded.
Changes, but still falls within the warning band, ...	The warning time is automatically adjusted.
Drops back out of the warning band, ...	The alarm will be cleared.

Example — High Alarm Warning Band

For an explanation of high alarm warning bands, follow the example below.

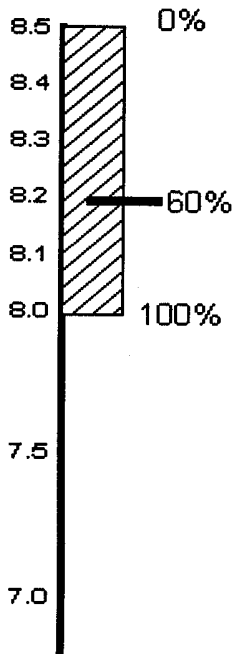

Figure 2.2

Scenario	
pH High Alarm =	8.5
Warning band =	0.5
Current pH reading =	8.2
pH high reading time	5.0 minutes

This current pH reading (8.2) is 60% away from high alarm.

Calculation:
 $(\text{High Alarm} - \text{Current Reading}) / \text{Warning Band}$
 $(8.5 - 8.2) / .5 = .6 = 60\%$

The proportional warning time will be 60% of the standard warning time.

Calculation:
 % from High Alarm * Warning Time
 $60\% * 5 \text{ minutes} = 3 \text{ minutes}$

Consequently, if the alarm counter exceeds 3 minutes, a high alarm occurs.

If the pH changes to 8.1 (before the 3 minute alarm), then System5F automatically re-adjusts the standard alarm warning time to a new proportional warning time:

Calculation:
 $(\text{High Alarm} - \text{Current Reading}) / \text{Warning Band}$
 $(8.5 - 8.1) / .5 = .8 = 80\%$

% from High Alarm * Warning Time
 $0.80\% * 5 \text{ minutes} = 4 \text{ minutes}$

In this case, the alarm counter will not reset because the pH changed **within** the warning band. Remember that the high alarm is the **absolute** high. Whenever the current reading exceeds the high alarm, a high alarm occurs regardless of any warning band time counters.

Example — Low Alarm Warning Bands

The **low alarm warning band** is very similar; however, the warning band is reversed.

Scenario	
pH High Alarm =	6.0
Warning band =	0.5
Current pH reading =	6.3
pH high reading time	5.0 minutes

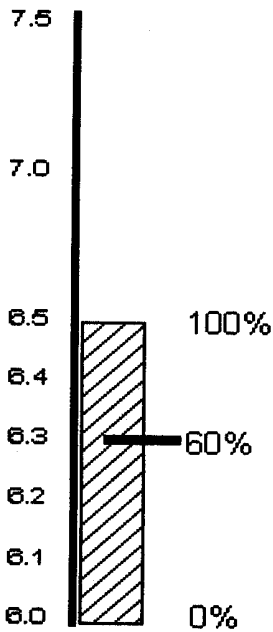

If current pH value remains at 6.3 for 3 minutes, a low alarm occurs.

Calculation:

$$(6.3 - 6.0) / .5 = .6 = 60\% \text{ away from setpoint}$$

$$0.60 * 5 \text{ minutes} = 3 \text{ minutes}$$

Figure 2.3

Recorder Outputs - Chapter 5

4-20 mA Outputs

The Strantrol System5F two-channel controller is capable of handling two or four analog outputs. Each of the channels can be independently configured for pH, HRR, ppm or temperature from within the menu system. Furthermore, the values corresponding to 4 mA and 20 mA (0-100%) can be specified for each channel, thus making the channel available as either a recorder or control output. All analog channels are configured in the same way.

EXAMPLE: Configure Channel #1 for recording pH from 6.0 to 9.0	
1	Enter menu system using Representative access code.
2	Select [RECORDER OUTPUTS: Channel #1 Recorder].
3	Select, by pressing the corresponding number to the left, which input Channel #1 will record or control. The choices are pH, HRR, ppm and Temperature. (For this example, choose pH.)
4	Select [RECORDER OUTPUTS: Channel #1 Recorder: Chan #1 Rec]. This is a display only of the current parameter to be recorded or controlled.
5	Select [RECORDER OUTPUTS: Channel #1 Recorder: Chan #1 Rec Min].
6	Select the minimum value to be recorded or controlled. (Select 6.0 for this example.) A pH of 6.0 = 4 mA output.
7	Select [RECORDER OUTPUTS: Channel #1 Recorder: Chan #1 Rec Max].
8	Select the maximum value to be recorded or controlled. (Select 9.0 for this example.) A pH of 9.0 = 20 mA output.

Channel #1 is now configured to record pH from 6.0 to 9.0.

The output signal is the same for control as it is for recording. Consult the factory if using outputs for control.

4-20 mA Linear Relationship

If the analog 4-20 mA output is being used for control, the following example explains the linear relationship that the Strantrol System5F utilizes.

NOTE: The control algorithm is proportional only.

EXAMPLE: Channel #1			
Channel #1 Recorder =	HRR	Output	%
Chan #1 Min =	500	4 mA	0%
Chan #1 Max =	900	20 mA	100%

The example shows with an HRR reading of 500 mV the controller will output a 4 mA signal. In addition, with an HRR reading of 900 mV the controller will output a 20 mA signal. Having understood this the halfway point would be the HRR reading 700 mV and the controller would be sending a 12 mA signal.

Menu Options - Chapter 6

Menu Tree v 5.10 — Reference Guide

This section outlines the options that may appear in the Strantrol System5F menus. The menu hierarchy is represented by the indented options. (For example, the pH Low Alarm can only be accessed from the Alarms menu.) Descriptions of each option can be found later in this chapter. Some options may not appear, depending on how your authorized Strantrol Representative set up your system. For this reason, symbols are used.

A plus (+) indicates that this option is ALWAYS present when you work through the menu system.

An asterisk (*) indicates that this option may not appear, depending on the system state.

An "R" indicates that this option appears ONLY under Strantrol Representative access.

The brackets { } indicate the default values that were shipped on the ROM chip.

- + pH SETUP
 - * pH feed down Setpoint {7.5}
 - * pH feed up Setpoint {7.5}
 - + pH High Alarm {8.0}
 - + pH Low Alarm {7.0}
 - * pH feed-down F/S {04:00 hr/min}
 - * pH feeddn Mode {on-off}
 - * pH prop span {.5}
 - * pH cycle time {01:00 min/sec}
 - + pH Calibrate

- + HRR SETUP
 - + HRR Setpoint {740mV}
 - + HRR High Alarm {800mV}
 - + HRR Low Alarm {650mV}
 - + HRR F/S Alarm {04:00 hr/min}
 - + HRR (Cl/Br) Feed Mode {proportional}
 - * HRR prop span {20 mV}
 - * HRR cycle time {01:00 min/sec}
 - + HRR/Cl ppm cntrl {HRR}
 - + HRR Calibrate

- + ppm SETUP
 - * Cl ppm Setpoint {1.5 ppm Cl}
 - + Cl ppm High Alarm {5.0 ppm Cl}
 - + Cl ppm Low Alarm {0.5 ppm Cl}
 - + Cl ppm Calibrate

- * TEMPERATURE SETUP
 - * Temperature Setpoint {80°F}
 - * Temperature High Alarm {90°F}
 - * Temperature Low Alarm {70°F}
 - * Temperature Calibrate

Technical Guide

- * CALCULATE LSI SETUP
 - * Based on {00/00/00}
 - * Calculated LSI {0.0}
 - * Alkalinity {0}
 - * Ca hardness {0}
 - * TDS {0}
 - * Temperature {32°F}
 - * pH {0.0}
 - * Enter LSI parameters
 - * Alkalinity {0}
 - * Ca hardness {0}
 - * TDS {0}
 - * Exit (don't compute LSI)
 - * Other LSI parameters
 - * Pool Size {0 gal}
 - * LSI Hi band {0.0}
 - * LSI Lo band {0.0}

- * RYZNAR STABILITY SETUP
 - * Based on {00/00/00}
 - * Ryznar Index {0.0}

- * DOSAGE CALCULATED
 - * Based on {00/00/00}
 - * Pool Size {0 gal}
 - * Pool is balanced: {No chemical treatment is needed now.}

- + SENSOR WASH
 - + current week/day
 - + Event #1 {every week/every day}
 - + Start Time #1 {23:59 hr/min}
 - + Wash Duration #1 {02:00 min/sec}
 - + Event #2 {disabled}
 - + Start Time #2 {00:00 hr/min}
 - + Wash Duration #2 {00:00 min/sec}
 - + Event #3 {disabled}
 - + Start Time #3 {00:00 hr/min}
 - + Wash Duration #3 {00:00 min/sec}
 - + Event #4 {disabled}
 - + Start Time #4 {00:00 hr/min}
 - + Wash Duration #4 {00:00 min/sec}

- + ALTERNATE HRR SETPOINT
 - + current week/day
 - + Event #1 {disabled}
 - + Alt. HRR Setpoint #1 {740 mV}
 - + Start Time {00:00 hr/min}
 - + Duration {00:00 hr/min}

- * DECHLORINATION
 - * current week/day
 - * Auto Dechlor {yes}
 - * Cl/HRR stop point {chlorine}
 - * Stop HRR point {750 mV}

* Stop Cl ppm point	{1.0 ppm Cl}
* Duration #1	{04:00 hr/min}
+ SUPER CHLORINATION	
+ current week/day	
+ SuperCl start day	{disabled}
+ Start Time	{00:00 hr/min}
+ Cl/HRR stop point	{chlorine}
* HRR setpoint	{800 mV}
* Cl ppm setpoint	{5.0 ppm Cl}
+ Duration	{00:04 hr/min}
+ Elapsed time	{00:00 hr/min}
+ RELAY MODES	
* pH feed down	{automatic}
* pH feed up	{automatic}
* Cl/Br feed	{automatic}
* Dechlor feed	{automatic}
* SuperCl feed	{automatic}
* Sensor wash	{automatic}
* Ozone	{automatic}
* Heater	{automatic}
* Cl/Br booster	{automatic}
+ COMMUNICATION	
+ Connection type	{direct}
+ Direct baud	{1200}
+ Modem baud	{2400}
+ MODEM CALL OUT	
+ Callout enable	{enable}
+ Callout Type	{fax}
+ Ring pickup	{1}
+ Call begin	{08:00 hr/min}
+ Call end	{17:00 hr/min}
+ Pre-delay	{30:00 min/sec}
+ Phone #1	{!}
+ Delay#1	{00:00 min/sec}
+ Phone #2	{!}
+ Delay#2	{00:00 min/sec}
+ Phone #3	{!}
+ Delay#3	{00:00 min/sec}
+ Phone #4	{!}
+ Delay#4	{00:00 min/sec}
+ Phone #5	{!}
+ Delay#5	{00:00 min/sec}
+ Phone #6	{!}
+ Delay#6	{00:00 min/sec}
+ CALENDAR	
+ Current date	{01/01/1997 mm/dd/yy}
+ Current time	{00:00 hr/min}

Technical Guide

- + ACCESS CODES
 - + MANAGER CODES
 - + Manager #1 {000}
 - + Manager #2 {000}
 - + OPERATOR CODES
 - + Operator #1 {000}
 - + Operator #2 {000}
 - + Operator #3 {000}
 - + Operator #4 {000}
 - + Operator #5 {000}
 - + Operator #6 {000}
 - + ENABLE OPTIONS FOR OPERATOR LEVEL
 - + Setpoints {enable}
 - + Alarms {enable}
 - + Feed Modes {enable}
 - + Calibrate pH, HRR {enable}
 - * Calibrate temperature {enable}
 - + LSI calculations {enable}
 - + Pool Size {enable}
 - + Sensor Wash {enable}
 - + Alt. HRR Setpoint. {enable}
 - + Dechlorination {enable}
 - + Super Chlor {enable}
 - + Relay Modes {enable}
 - + Communication {enable}
 - + Modem Call Out {enable}

- R+ RECORDER OUTPUTS
 - + Channel #1 Recorder
 - + Chan #1 Rec {pH}
 - + Chan #1 Rec Min {6.0}
 - + Chan #1 Rec Max {9.0}
 - + Channel #2 Recorder
 - + Chan #2 Rec {HRR}
 - + Chan #2 Rec Min {0 mV}
 - + Chan #2 Rec Max {1000mV}
 - + Channel #3 Recorder
 - + Chan #3 Rec {ppm}
 - + Chan #3 Rec Min {0.0 ppm Cl}
 - + Chan #3 Rec Max {20.0 ppm Cl}
 - + Channel #4 Recorder
 - + Chan #4 Rec {Temp}
 - + Chan #4 Rec Min {60°F}
 - + Chan #4 Rec Max {100°F}

- R+ DIAGNOSTICS
 - + Version
 - + Program Version {v5.10*}
 - + Factory Defaults
 - + Software Calibration
 - + pH point 1 cal
 - + pH point 2 cal
 - + HRR Point 1 Cal
 - + HRR Point 2 Cal
 - + Cyanuric {disable}

+ Alt ppm Lookup	{disable}
* pH for ppm lookup	{7.5}
+ Lookup offset	{250}
+ Temp point1 cal	
+ Temp point2 cal	
+ Temperature units	{°F}
+ Units (US/ metric)	{U.S.}
+ Hardware Calibration	
+ Temperature	{disable}
+ Connection Type	{direct}
+ Direct Baud	{1200}
+ Modem Baud	{2400}
R+ WARNING BANDS	
+ pH hi band	{0.0}
+ pH hi warn time	{00:05 hr/min}
+ pH lo band	{0.0}
+ pH lo warn time	{00:05 hr/min}
+ HRR hi band	{0 mV}
+ HRR hi warn time	{00:05 hr/min}
+ HRR lo band	{0 mV}
+ HRR lo warn time	{00:05 hr/min}
+ Cl ppm hi band	{0.0 ppm Cl}
+ Cl ppm hi warn tm	{00:05 hr/min}
+ Cl ppm lo band	{0.0 ppm Cl}
+ Cl ppm lo warn tm	{00:05 hr/min}
R+ DATA LOGGING	
+ High frequency	{Every 6 minutes}
+ Low frequency	{Every 2 hours}
+ Print time intrvl	{01:00 hr/min}
R+ REP. STARTUP	
+ Current date	{01/01/1997 mm/dd/yy}
+ Current time	{00:00 hr/min}
+ System ID	{0}
+ customer name	{!}
+ system location	{!}
+ rep phone num	{!}
+ Startup date	{00/00/00}
+ Rep code	{000}
+ Relay #1	{pH feed-down}
+ Relay #2	{sensor wash}
+ Relay #3	{Cl/Br}
+ Relay #4	{alarm}
* pH feeddn Point	{7.5}
* pH feedup Point	{7.5}
+ pH High Alarm	{8.0}
+ pH Low Alarm	{7.0}
* pH feeddn Mode	{on-off}
* pH feedup Mode	{on-off}
+ HRR/Cl ppm control	{HRR}
* HRR Setpoint	{740 mV}
+ HRR High Alarm	{800 mV}
+ HRR Low alarm	{650 mV}

Technical Guide

* HRR (Cl/Br) Mode	{proportional}
* Cl ppm setpoint	{1.5 ppm Cl}
+ Cl ppm High Alarm	{5.0 ppm Cl}
+ Cl ppm Low Alarm	{0.5 ppm Cl}
* Cl ppm Feed Mode	{proportional}
+ Cyanuric	{disable}
+ LSI	{enable}
+ Ryznar	{enable}
+ TDS	{enable}
+ Dosage	{enable}

Menu Tree v 5.10 — Definitions

The menu options in the front of this chapter are shown in the order that they appear in the Menu Tree structure. Factory defaults are listed in the right column of the Menu Tree pages.

Option Name	Description
pH SETUP	Title text only. Houses all pH control parameters.
pH feed down Setpoint	For feeding a chemical (like acid) that will cause the pH to decrease.
pH feed up Setpoint	For feeding a chemical (like base) that will cause the pH to increase.
pH High Alarm	The high alarm triggers when the pH reaches this amount.
pH Low Alarm	The low alarm triggers when the pH drops to this amount.
pH feed-down F/S Alarm pH feed-up F/S Alarm	The amount of time that the feeder will feed continuously without achieving setpoint before it stops feeding and alarms.
pH feeddn Mode pH feedup Mode	Describes whether the pH control relay is in proportional mode or on/off mode.
pH prop span	The proportional span for the pH relay.
pH cycle time	The total time the feeder will be both on and off while in proportional mode cycle.
pH Calibrate	Use a test kit to determine actual pH and type it in.
HRR SETUP	Title text only. Houses all HRR control parameters.
HRR feed down setpoint	For feeding a chemical (like dechlor) that will cause the HRR to decrease.
HRR feed up setpoint	For feeding a chemical (like chlorine or bromine) that will cause the HRR to increase.
HRR High Alarm	The high alarm triggers when the HRR reaches this amount.
HRR Low Alarm	The low alarm triggers when the HRR drops to this amount.
HRR F/S Alarm	The amount of time that the feeder will feed continuously without achieving setpoint before it stops feeding and alarms.
HRR prop span	If HRR control mode is selected, this option sets the proportional span for the HRR control.
HRR cycle time	The total time the feeder will be both on and off while in proportional mode.
HRR/Cl ppm cntrl	Mode of control for process chlorine. <i>If HRR is selected, the control is based from the HRR setpoint.</i> <i>If ppm is selected, the control is based from the derived value.</i>
HRR (Cl/Br) Feed up/down Mode	If HRR control mode is selected, this option sets what type of control is needed.

Technical Guide

HRR Calibrate	Allows Representative to align HRR on controller to HRR on mV generator.
ppm SETUP	Title text only. Houses all Cl ppm control parameters.
Cl ppm High Alarm	Alarm that warns user when Cl ppm is too high.
Cl ppm Low Alarm	Alarm that warns user when Cl ppm is too low.
Cl ppm Calibrate	Allows user to align Cl ppm readout to water test.
TEMPERATURE SETUP	Title text only. Houses all Temperature control parameters. Temperature must be enabled.
Temperature Setpoint	Desired temperature of water. Relay must be assigned to heater.
Temperature High Alarm	Alarm that warns user when Temperature is too high.
Temperature Low Alarm	Alarm that warns user when Temperature is too low.
Temperature Calibrate	Allows user to align Temperature readout to actual water temperature.
CALCULATE LSI SETUP	Title text only. Houses all LSI parameters to be entered by user.
Based on	Date that the LSI was last calculated.
Calculated LSI	LSI from the last calculation.
Alkalinity	Alkalinity of the last LSI calculation.
Ca Hardness	Ca Hardness of the last LSI calculation.
TDS	TDS of the last LSI calculation. TDS is normally done by a lab.
Temperature	Temperature of the last LSI calculation from probe.
pH	pH of the last LSI calculation from probe.
Enter LSI Parameters	Title text only. Parameters to be entered to calculate LSI.
Alkalinity	Entered after a test kit reading.
Ca Hardness	Entered after a test kit reading.
TDS	From test kit or enter zero.
Sensor wash	Title text only. This is only present when one of the relays has been assigned to sensor wash.
Current week/day	This is a read only value of the current week and day.
Event #1	<p>You may choose the first sensor wash to be in the first, second, third or fourth weeks of operation (sensor wash operates on a four-week calendar). You may choose it occur in even or odd weeks, every week or disable it completely. Enter in day - Mon., Tues., Wed., Thurs., Fri., Sat., Sun. or All days.</p> <p>NOTE: Each event for the sensor wash (-2, -3, -4) has the identical description as -1 above.</p>

Start Time #1	Enter the time you would like the first sensor wash to begin using military time (24-hour clock). NOTE: Each start time for the sensor wash (-2, -3, -4) has the identical description as -1 above.
Wash Duration#1	Enter the duration of the first sensor wash from 0 to 2 minutes. NOTE: Each wash duration for the sensor wash (-2, -3, -4) has the identical description as -1 above.
Alternate HRR Setpoint	Title text only. Houses all parameters for the alternate HRR setpoint function.
Current week/day	This is a read only value of the current week and day.
Event #1	You may choose the alternate HRR setpoint to be in the first, second, third or fourth weeks of operation. You may choose it occur in even or odd weeks, every week or disable it completely. Enter in day - Mon., Tues., Wed., Thurs., Fri., Sat., Sun. or All days. NOTE: Each event for the alternate HRR setpoint (-2, -3, and -4) has the identical description as -1 above.
Alt. HRR Setpoint	This is the alternate setpoint.
Start Time	Enter the time you would like the Alternate setpoint to begin using military time (24-hour clock).
Duration	Enter how long you would like the Alternate Setpoint to be in effect (number of hours and minutes).
Dechlorination	Title text only. Houses all parameters for the Dechlorination function. This is only present when one of the relays has been assigned to dechlorination.
Current week/day	This is a read only value of the current week and day.
Auto Dechlor	Yes if you want dechlorination to automatically begin after the superchlorination process and No if, you don't..
Cl/HRR stop point	The Chlorine or HRR point at which the process will stop.
Duration	How long you want the process to last in hours and minutes. This functions as a failsafe timer, stopping the process after a certain time even if the stop setpoint has not yet been reached.
Superchlorination	Title text only. Houses all parameters for the Superchlorination function. This is only present when one of the relays has been assigned to superchlorination.
Current week/day	This is a read only value of the current week and day.
SuperCl start day	You may choose the first super chlorination to be the first, second, third or fourth weeks of operation. You may choose to have it occur in only even or odd weeks, every week or disable it completely. Enter in day - Mon., Tues., Wed., Thurs., Fri., Sat., Sun. or All days.
Start Time #1	Enter the time you would like the super chlorination to begin using military time.
Cl/HRR stop point	Do you want to use chlorine or HRR setpoint to stop the process.
Duration	How long you want the process to last in hours and minutes. This functions as a failsafe timer, stopping the process after a certain time even if the stop setpoint has not yet been reached.
Elapsed Time	The time since the process began.

Technical Guide

Relay Modes	Title text only. This menu displays what function the relays are operating and what mode the relay is currently.
pH Feed down	For pH control.
pH Feed up	For pH control.
Cl/Br feed	For disinfection control.
Cl/Br booster	A booster is a secondary feed device that comes on a low alarm.
Heater	For Temperature control.
Dechlor	To quickly lower ppm residual valve after superchlor.
SuperCl	To eliminate ammonia in pool.
Sensor wash	To auto clean the Sensors.
Alarm	General alarm to signal horn, etc...
Ozone	To feed ozone for the disinfection process.
Communication	Title text only. Provides the parameters that the controller uses to communicate.
Connection type	Based on Dip Switch #5.
Direct baud rate	Select the correct baud rate for direct.
Modem baud rate	Select the correct baud rate for modem.
Modem Callout	Title text only. If the controller has a Voice modem, this menu will allow to enable and specify the restrictions for the controller to follow when calling out. DipSwitch #6 needs to be on to see this option.
Callout enable	Select enable if you want the modem to call out..
Ring Pickup	Number of rings the modem allows before answering.
Call begin	The time the modem will begin calling.
Call end	The time the modem will stop calling.
Pre delay	The amount of time the controller waits after an alarm before calling.
Phone #1....6	The telephone number and Pager message will call out (up to six different telephone numbers).
Delay #1....5	The amount of time the modem will wait before going to the next telephone number.
Calendar	Title text only. This option will display the current date and time.
Current Date	Enter the current date as follows: month/day/year.
Current Time	Enter the current date as follows: hour/minutes.
Access Codes	Title text only. This option allows the user to enter in access codes for managers and operators. For both manager and operator access the controller will not require a code if no code has been programmed.
Manager Codes	Three digit codes may be entered for up two different managers.
Operator Codes	Three digit codes may be entered for up six different operators.
Enable options for operator level	Operators may be enabled to have access to Main Menu.
Data Logging	Title text only. Sub-menu appears when <i>Select/Enter</i> key is pressed.

Chan #1...4 Rec	Selects which item that the first 4-20 mA output will record or control. The options are pH, HRR, ppm, temperature.
Chan #1...4 Min	Selects minimum value to be recorded. For example, if pH is selected and this value is set at 6, the bottom of the recorder or controller (4 mA) will represent a pH of 6.
Chan #1...4 Rec Max	Selects maximum value to be recorded. For example, if pH is selected and this value is set at 9, the top of the recorder or controller (20 mA) will represent a pH of 9. NOTE: Each Chan output (#2, #3, and #4) has the identical description as Chan #1 min and Chan #1 max above.
Diagnostics	Title text only. If the <i>Select/Enter</i> key is pressed, a sub-menu is displayed. This is present using a Representative access code only.
Program Version	Display only if ROM software version present in the controller.
Factory Default	[Factory Default] Command that allows all parameters to be reset to factory calibration. The <i>Select/Enter</i> key must be pressed twice to avoid accidental engagement.
Software Calibration	Title text only. If the <i>Select/Enter</i> key is pressed, a sub-menu is displayed. This is present ONLY using a Representative access code.
pH point 1 cal	Use a buffer solution or signal generator to generate a pH point, wait 30 seconds and type it in.
pH Point 2 Cal	Use a buffer solution or signal generator to generate a second, higher pH point, wait 30 seconds and type it in.
HRR Point 1 Cal	Use a signal generator to generate an HRR point, wait 30 seconds and type it in.
HRR Point 2 Cal	Use a signal generator a second, higher HRR point, wait 30 seconds and type it in.
ppm Point 1 Cal	Use a buffer solution to generate a ppm point, wait 30 seconds and type it in.
ppm Point 2 Cal	Use a buffer solution to generate a second ppm point, higher point, wait 30 seconds and type it in.
Cyanuric	Enable if using stabilizer in pool.
alt ppm lookup	This uses a fixed pH for the lookup table.
Lookup offset	250 mV is defined as 0 ppm. Any difference represents how much the unit has been calibrated. WARNING: A 50 mV difference or more.
Temp point 1 Cal	Use a signal generator or buffer solution to generate a Temp point, wait 30 seconds and type it in. Press Enter.
Temp Point 2 Cal	Use a signal generator or buffer solution to generate a second, higher, Temp point. Wait 30 seconds and type it in. Press Enter.
Temperature Units	Fahrenheit (F) or Centigrade (C).
Units (US/metric)	Select U.S. or Metric units for dosage calculations.
Hardware Calibration	Title text only. Includes temperature enable or disable and communication parameters.
Temperature	You must enable temperature in order to use a temperature sensor with the system and see temperature menu.
Connection Type	This is a display only of the current connection type as selected by the controller or the PC software.

Technical Guide

Direct baud	The com port on your PC talks to the controller com port at this baud rate. The max setting is 19200.
Modem Baud	The modem talks to the PC at this baud rate. Currently, the Data Modem is 33,600 baud; the Data/Voice modem is 2400 baud.
Warning Bands	Title text only. Warning bands provide a series of gradual alarms over a time period. They alert the user before water gets too far out of control.
pH hi band	High end pH alarm that will trigger before the actual alarm.
pH hi warn time	The time the warning band will sound and wait before triggering the actual alarm.
pH lo band	Low end pH alarm that will trigger before the actual alarm.
pH lo warn time	The time the warning band will sound and wait before triggering the actual alarm.
HRR hi band	High end HRR alarm that will trigger before the actual alarm.
HRR hi warn time	The time the warning band will sound and wait before triggering the actual alarm.
HRR lo band	Low end HRR alarm that will trigger before the actual alarm.
HRR lo warn time	The time the warning band will sound and wait before triggering the actual alarm.
Cl ppm hi band	High end Cl ppm alarm that will trigger before the actual alarm.
Cl ppm hi warn time	The time the warning band will sound and wait before triggering the actual alarm.
Cl ppm lo band	Low end Cl ppm alarm that will trigger before the actual alarm.
Cl ppm lo warn time	The time the warning band will sound and wait before triggering the actual alarm.
Datalogging	Title text only. Specifications for the controller to follow while datalogging information.
High Frequency	Information will be recorded in 1 - 6 minute intervals.
Low Frequency	Information will be recorded in 1 - 4 hour intervals.
Print time Interval	Specify when the controller is to print out the water parameters.
Rep Start Up	Title text only. Quick controller setup menu.
Current Date	Current date shown as mm/dd/yy
Current Time	Current time shown as 0-24:00
System ID	Type in the serial number of the unit here.
Customer Name	The name entered here will show on the facepanel
System Location	Location entered here will show on the facepanel.
Rep Phone Num.	Number entered here will show on the facepanel.
Startup Date	This is the date the unit was put into use.
Rep. Code	This is the access code of the Rep.
Relay #1 . . . 4	Relays may be configured as pH Feed down, pH Feed up, Cl/Br Feed Cl/Br booster, heater, Dechlor feed, SuperCl feed, Sensor Wash, Alarm and Ozone.
pH High Alarm	The pH High Alarm point.

Menu Options

pH Low Alarm	The pH Low Alarm point.
pH Mode	pH feeding on/off or proportional
HRR/Cl ppm control	The form of control you wish.
HRR setpoint	The HRR setpoint.
HRR High Alarm	The HRR High Alarm point.
HRR Low Alarm	The HRR Low Alarm point.
HRR (Cl/Br) Mode	HRR feeding on/off or proportional.
Cl ppm High Alarm	The range for ppm is 0-20 if you have a ppm sensor and 0-6 if you do not..
Cyanuric	Cyanuric acid lowers the HRR disinfection values. This value is configured for levels between 10 - 20 ppm of Cyanuric.
LSI, Ryznar, TDS, Dosage	If you disable LSI, then LSI, Ryznar, TDS (Total Dissolved Solids) and Dosage will not appear under Manager Access.

SENSOR WASH OPTION - Chapter 7

Sensor Wash

If the optional sensor wash is used, install the plumbing and configure the system for Sensor Wash use.

NOTE: For most applications, the default settings need not be changed.

Configure Sensor Wash

1. Choose one of the unused relays and assign it to sensor wash. Select Menu: [rep startup], the default sensor wash relay is #2.
2. Connect the feed device to the appropriate relay output.
3. Enter [Sensor Wash] sub-menu to modify the sensor wash settings.

Programming Sensor Wash

After the sensor wash option is enabled, steps must be taken to program the automatic sensor wash. The System5F automatic sensor wash program is based on:

- A four-week cycle that does not correspond to the day and week of the calendar.
 - The cycle begins with Sunday, week 1, and ends with Saturday, week 4.
- A 24-hour clock
 - Add 12 hours to calculate afternoon and evening times.
- Sensor Wash should be done on a daily basis. Time should be set for All week/Every day.
 - The operator should select time of day.
- Four programmable times that allows you to select 4 days out of selected weeks to run feed device.

NOTE: There is only one “on-line” duration setting.

- Start times are based on two components:
 - week and day
 - hour and minutes

Menu Displays

An explanation of the controller displays is presented in the following table.

Controller Choices		
Characters Shown on Display	Description	Days of the week
1 st week	week 1	Monday
2 nd week	week 2	Tuesday
3 rd week	week 3	Wednesday
4 th week	week 4	Thursday
Odd week	odd number week	Friday
Even week	even number week	Saturday
Every week	All weeks	Sunday
disabled	No sensor wash	Everyday

Technical Guide

EXAMPLE: Program the sensor wash system to wash the sensors every Monday, at 1:00 p.m., and every Thursday at 6:00 a.m.

	Before programming a sensor wash cycle, verify that all steps in Configure Sensor Wash have been completed.
1	Enter the menu system using a Manager or Representative Level access code.
2	Select [Sensor Wash].
3	Select [Wash Duration].
4	Select the duration of sensor wash. If you select 2 minutes, then the sensor wash feed device will run for two minutes.
5	Select [Event #1].
6	Select [every week] and [Monday]. This means that on Monday of every week, the sensor wash feed device will engage at the designated time.
7	Select [Start time #1].
8	Enter [13:00]. (13.00 in military time represents 1.00 p.m.)
9	Select [Event #2].
10	Select [every week] and [Thursday]. This means that on Thursday of every week, the sensor wash feed device will engage at the designated time.
11	Select [Start time #2].
12	Select [06:00]. (06:00 represents 6:00 am)

NOTE: This example is being used to demonstrate how the sensor wash timer is set-up. Sensor wash should be initiated every day.

Superchlorination - Chapter 8

Superchlorination Programming

The System5F superchlorination program features a single programmable time used to start the superchlorination procedure. To obtain superchlorination one of the four relays must be assigned to superchlorination. This start time is based on:

- A four-week cycle that does NOT correspond to the day and week of the calendar.
- A 24-hour clock.
- Two components
 - week and day
 - hour and minutes

An example programming situation is outlined later in this section.

Superchlorination Functionality

Normal alarms, fail/safes, and lockouts **are not active** during superchlorination feed.

When superchlorination starts, programming temporarily suspends the normal HRR or ppm control and takes over the chlorine (or bromine) control relay (relay #3). This relay is activated and stays active until the input reading is driven up to the superchlorination point.

- If the superchlorination point is NOT reached by the end of the time set as fail/safe, an alarm [SuperCl limit] triggers.
- If the HRR value drops below the normal control setpoint, control will resume. Pressing the Reset Fail/Safe is not necessary or required in this case.

You can reset this fail/safe alarm from the front panel:	Or, you can ignore the alarm:
Press the <i>RESET FAIL/SAFE</i> key (on the front panel). This resets all fail/safes.	After ppm or HRR, values reach normal levels....
Control will automatically resume (even if the Fail/Safe timer has NOT been reset).	

You can determine whether superchlorination timed out by looking at the [Elapsed Time].

EXAMPLE: Program a superchlorination for Tuesday at 2:00 p.m. every fourth week.	
1	Enter the menu system using a Manager or Representative access code.
2	Select [superchlorination]. The current week and day of the cycle is displayed. The day of the cycle should correspond to the current day of the week. If this is not the case, consult authorized USFilter Stranco Products personnel.
3	Select [SuperCl start day].
4	Select [4 th week] and [Tuesday]. This means that on Tuesday of every 4 th week, the superchlorination feed device will engage at the designated time.
5	Select [Start Time]. Enter [14:00]. (14:00 in military time represents 2:00 p.m.)
6	Select [Cl/HRR stop point]. Select the control of superchlorination. [chlorine] or [HRR]
7	Select [Cl ppm setpoint] or [HRR setpoint] depending on what you selected for the stop point. Enter in value that you wish the controller to superchlorinate.
8	Select [Duration]. Select the duration of superchlorination. If you select 2 hours, then the superchlorination feed device will run for two hours before triggering the F/S alarm.
9	[Elapsed Time] If the controller is in the middle of superchlorination (and the feed device is ON), this value represents how long the feed device has been running. If the feed device is not on, this value is equal to the prior [superchlorination time to complete]. For example, if the superchlorination setpoint is set to 800 mV, and superchlorination is reached in two hours, the value displayed will be 2 hours.

Calculate LSI Setup - Chapter 9

LSI Programming

LSI

The System5F will calculate and display a LSI after the user has entered certain water chemistry values. After the user has entered a value, an asterisk will appear next to the value. **The LSI will only be calculated after all values have been entered or updated.**

Ryznar Index

The System5F will calculate and display a Ryznar Index after the user has entered the values that were previously entered for the LSI. The values only need to be entered once for the calculation of both Ryznar and LSI.

NOTE: All the parameters must be re-entered with every new calculation. Even if only one parameter has changed, all must be re-entered.

Dosage Calculated

The System5F will calculate and display the chemicals needed for a balanced pool.

Technical Guide

EXAMPLE: Entering values for LSI and Ryznar Index calculations		
1	Enter the menu system using a Operator, Manager or Representative access code.	
2	Select [Calculate LSI Setup].	
3	Select [Enter LSI parameters].	
4	Select [Alkalinity] then enter.	Enter test kit reading.
5	Select [Ca hardness] then enter.	Enter test kit reading.
6	Select [TDS] then enter.	Most pools are from 1500 to 2500. This value doesn't have a big affect on calculations, so TDS doesn't have to be accurate.
NOTE: An asterisk must be on the right side of each value for step # 7 to appear.		
7	Select [Compute LSI and Exit].	
8	Select [Enter other parameters].	
9	Select [Pool Size] then enter.	Enter in approximate volume of pool.
10	Select [LSI Hi band] then enter.	Usually .5
11	Select [LSI Lo band] then enter.	Usually 0.
12	Press Previous Screen button until the Main Menu is displayed.	
13	Select [Ryznar Stability Setup].	Date of Calculation and Ryznar will be displayed.
14	Press Previous Screen button until the Main Menu is displayed.	
15	Select [Dosage Calculated].	Date of Calculation, Pool Size and what chemicals are needed to balance pool plus quantities.

Alternate HRR Setpoint - Chapter 10

Alternate HRR Setpoint Programming

The System5F alternate HRR setpoint program features a single programmable time used to start the alternate HRR setpoint procedure. To obtain alternate HRR setpoint the time must be enabled and the timer set. No relay is assigned. This start time is based on:

- A four-week cycle that does NOT correspond to the day and week of the calendar.
- A 24-hour clock.
- Two components
 - week and day
 - hour and minutes

An example-programming situation is outlined later in this section.

Alternate HRR Setpoint Functionality

Normal alarms, fail/safes, and lockouts **are active** during an alternate HRR feed.

When alternate HRR setpoint starts, programming temporarily suspends the normal HRR or ppm control and takes over the chlorine (or bromine) control relay (relay #3). The Alternate Setpoint is activated and stays active through the duration time desired.

EXAMPLE: Program an alternate HRR setpoint for Tuesday at 8:00 p.m. until 9:00 a.m. every first week.	
1	Enter the menu system using an Operator, Manager or Representative access code.
2	Select [Alternate HRR Setpoint]. The current week and day of the cycle is displayed. The day of the cycle should correspond to the current day of the week. If this is not the case, consult authorized USFilter Stranco Products personnel.
3	Select [Event #1].
4	Select [1 st week] and [Tuesday]. This means that on Tuesday of every 1 st week, the alternate HRR will engage at the designated time.
5	Select [Alt. HRR Setpoint]. Enter Alternate HRR Setpoint.
6	Select [Start Time]. Enter [20:00]. (20:00 in military time represents 8:00 p.m.)
7	Select [Duration]. Enter [13:00]. (13:00 is hours from start time)

Dechlorination Setpoint - Chapter 11

Dechlorination Programming

The System5F dechlorination program is activated only after Superchlorination is done. If a relay is assigned and Dechlor is enabled the Auto Dechlor will be activated.

Dechlorination Functionality

Normal alarms, fail/safes, and lockouts **are not active** during a dechlorination feed.

The dechlorination relay is a separate relay and needs to be assigned for activation through Representative Access. When dechlorination starts, programming temporarily suspends the normal HRR or ppm control. This relay is activated only after a Super Cl₂ and stays active until the HRR or Cl ppm reaches stop setpoint or until fail/safe time is reached.

EXAMPLE: Program a dechlorination for 2:00 hours after superchlorination.	
1	Enter the menu system using an Operator, Manager or Representative access code.
2	Select [Dechlorination]. The current week and day of the cycle is displayed.
3	Select [Cl/HRR stop point]. Dechlorination can be controlled by either Cl or HRR.
4	Select [Stop HRR or Cl point]. Dechlorination will stop and regular control will engage at this point.
5	Select [Duration]. Enter [2:00]. (2:00 means hours from start time)

CI/Br Booster Option - Chapter 12

CI/Br Booster Functionality

Normal alarms, fail/safes, and lockouts **are active** during a CI/Br Boost feed.

The CI/Br Booster is activated when the HRR low alarm is triggered. When the CI/Br Booster starts, both the CI/Br feed device and the CI/Br Booster work together to bring the HRR value above the low alarm and to feed setpoint. The CI/Br booster feed device is programmed by assigning a relay. In addition to assigning a relay, that relay must be wired to an extra CI/Br feed device. The wiring for the extra feed device is done in the same manner as the other feed devices, only to a different relay. The following example shows how to assign the relay.

EXAMPLE: Assigning CI/Br boost feed device to a relay.	
1	Enter the menu system using a Representative access code.
2	Select [Rep Startup].
3	Select Relay #1 thru #4 NOTE: Relays #2 thru #4 will be on the second page.
4	From the list choose CI/Br booster.
5	Now if a heavy load occurs and HRR drops to a low alarm point, the boost feed device will begin to feed device and help the existing feed device increase the HRR level to setpoint.

Communication Capabilities - Chapter 13

Communication Functionality

The user has the ability to communicate the System5F through either direct connection or telephone connection.

Direct Connection is done with a direct connection cable (RS-232). Direct connection is meant for communication up to 50'. To properly direct connect the dipswitch #5 on S5 should be in the OFF position and the dipswitch labeled COM SELECT on the modem board should be switched to PC-CON. The purpose of a direct connection is to communicate with the controller without a telephone line.

Data Modem Connection is done with an **analog** telephone line. Data modem connection is meant for the computer to call up the controller and communicate. The data modem connection also can be programmed to call the operator's pager or fax out in case of any alarm conditions. To properly connect via data modem the dipswitch #5 on S5 should be in the ON position and the dipswitch labeled COM SELECT on the modem board should be switched to PHONE. **The Data Modem is standard in all System5F units.**

Voice Data Modem Connection (Optional) is done with an **analog** telephone line. Voice data modem connection is meant for the computer and/or telephone to call up the controller and communicate. The operator may use a telephone to find out parameters of the controller by selecting options given to the operator from the controller. The voice data modem connection also can be programmed to call the operator's telephone and/or pager in case of any alarm conditions. To properly connect via voice data modem the dipswitch #5 and #6 on S5 should be in the ON position.

Programming the Call Out Feature

Press enter to Access Menu.	
Press 9 for rep access.	
Press access code.	
Press 9 for more choices.	
Press the number to the left that corresponds to modem callout.	
Select Ring pickup.	Ring pickup tells the controller to wait before transmitting.
Select Call begin.	Call begin tells the controller that the calling can only begin after this time.
Select Call end.	Call end tells the controller that the calling cannot be done after this time.
Select Pre-delay.	Pre-delay is the time that the controller will be in alarm before calling out.
Select Phone#1.	1 st number to be called.
Voice and Data Modem Example: 5551212,,,,,1234	This method will call a pager and dial 1234 for the pager to read. The commas are for the delay if the pager has a message before the tone. Each comma is two seconds of delay.
Voice Data Modem only Example: 555-1212	This method will call a telephone, give the alarm, and ask for an access code so you can hear the parameters.

Programming the Fax Out Feature

Enter menu system by using Manager or Representative access	
Press 9 for More Choices	
Press the number that corresponds to Modem Call Out	
Select Callout Type	
Select Fax	
Select Ring pickup	Ring pickup tells the controller to wait for the number of rings before transmitting.
Select Call begin	Call begin tells the controller that the calling can only begin after this time.
Select Call end	Call end tells the controller that the calling cannot be done after this time.
Select Pre-Delay	Pre-delay is the time that the controller will be in alarm before calling out.
Press 6 for Phone #1	
Enter Fax machine number Example: 5551212	System5F will fax out the following: System ID Customer Name System Location Alarm:

Programming the Pager Out Feature

Enter menu system by using Manager or Representative access	
Press 9 for More Choices	
Press the number that corresponds to Modem Call Out	
Select Callout Type	
Select Pager	
Select Ring pickup	Ring pickup tells the controller to wait for the number of rings before transmitting.
Select Call begin	Call begin tells the controller that the calling can only begin after this time.
Select Call end	Call end tells the controller that the calling cannot be done after this time.
Select Pre-Delay	Pre-delay is the time that the controller will be in alarm before calling out.
Select Phone #1	
Enter Pager number and numeric message Example: 5551212,,,,1234	System5F will call the pager and leave 1234 on the display

Voice Data Modem Terminology & Operations

Dial In Your staff can always call up (or dial) the Voice Data Modem via telephone or modem.

Call Out You have the choice of setting up the Voice Data Modem to call out pool facility staff members in the event of an alarm. You program the list of staff phone numbers for the Voice Data Modem to call. Staff answering the call will hear a synthesized voice presenting an alarm report.

Enabling the call out allows the Voice Data Modem to dial out to facility staff.

Disabling the call out means that the Voice Data Modem will not be able to call your staff.

Access Code When you call in or when the Voice Data Modem calls out, you will be asked to enter your access code. The Manager Level access code is the same as the one used on the System5F controller keypad, followed by the pound (#) sign. Manager Level access allows users to change Voice Data Modem AND System5F settings.

If you wish, staff can also use an access that allows them to only monitor the System5F and listen to reports. Use access code ##. Anyone using ## will NOT be able to modify Voice Data Modem or System5F settings.

Overall Delay The overall delay value sets the amount of time that the Voice Data Modem will wait to begin calling down the call out list AFTER an alarm has been activated.

Data Mode If you have a PC, you can use Strantrol Virtual Controller (SVC) software to call your Voice Data Modem. This offers an alternative programming method for customizing the Voice Data Modem settings. If you do not have SVC, programming the Voice Data Modem will be done from the System5F facepanel.

Decimal Placement for Values Entered Decimal Points are added automatically because the decimal placement logic is built into the Voice Data Modem factory programming. For example, when entering the pH feed point, pressing 75# will be interpreted as 7.5.

Carrier The carrier tone is the long beep that you hear before the PC connects to the Voice Data Modem.

Enabling the carrier allows users to "call in" using a computer (SVC) or a telephone.

Disabling the carrier allows users to "call in" using only the telephone.

SAVE or ENTER All data entered on the telephone touch tone pad must be followed by the # button. For example:

The Voice Data Modem says:	You Enter:
"Please enter pH feeedown point"	75#
"Please enter ring pickup value"	4#
"You are about to Enable [option], press # to confirm."	#
"You are about to Disable [option], press # to confirm."	#

When you call the Voice Data Modem, you will be working with a simple menu structure

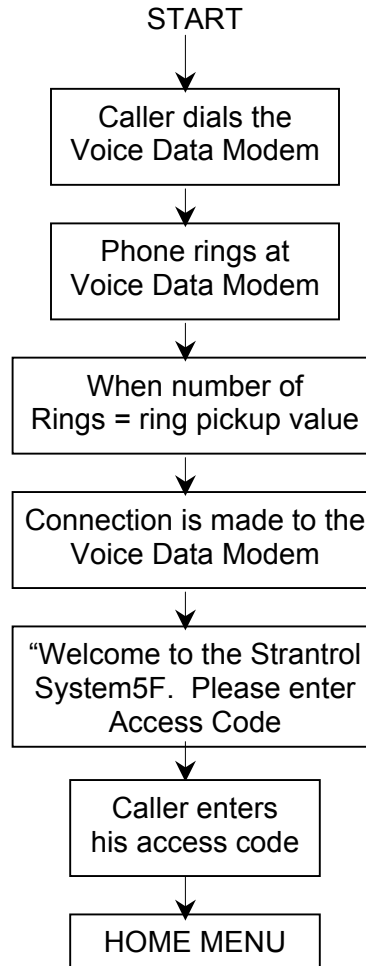

See the ACCESS CODE section.

See the flowchart on the next page for HOME MENU.

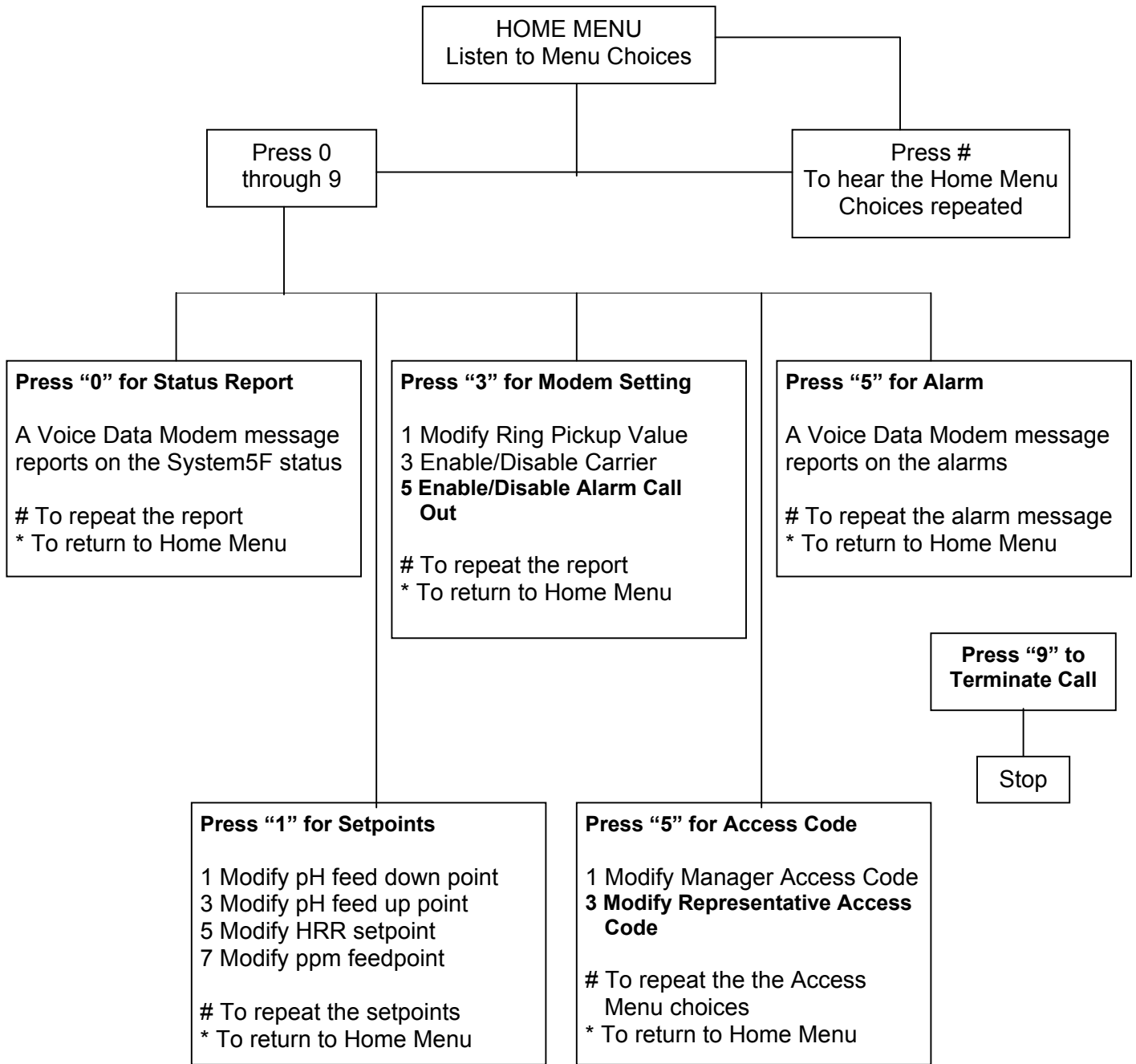

To Call into the Voice Data Modem for Reports

Staff can call in at any time to hear a Voice Data Modem report:

- a. Dial in and hear the welcome greeting.
- b. Enter the access code, then the # key.
- c. At the home menu level, press:

0 for a status report
7 for an alarm report

Set up the Voice Data Modem to Call Out

Enable the Alarm Call Out You can enable the alarm call out setting from either a Voice Data Modem call in or from the System5F controller.

If you use the Voice Data Modem: (Remote connection)	If you use the System5F keypad:
a. Dial in and hear the welcome greeting.	a. Enter the menu system.
b. Enter a manager or representative access code.	b. Enter your manager or representative access code.
c. At the home menu level, press 3 to access modem settings.	c. Find [Voice Menu] option and press corresponding number.
d. Press 5 to modify the Alarm Call Out setting.	d. Find the [Call Out] option and press corresponding number.
e. Press 3 to enable the call out. The Voice Data Modem will warn that you are about to enable (or disable) the call out. Press # to confirm that you want to make the change.	e. Select [Enable] or [Disable].

Train Staff

To get facility staff ready to use the Voice Data Modem follow the steps listed below:

- a. Inform staff of their access code.
- b. Point out the flow charts of the Voice Data Modem menus (on page 4 and 5 of this section).
- c. Copy and distribute the quick reference guides at the back of this section.

Customize the Ring Pickup Value

Default = 1

The ring pickup value controls the number of times the Voice Data Modem will 'ring' before an incoming call will be connected. (You may need to change this value if your facility is using phone switching equipment.)

- a. Dial in and hear the welcome greeting.
- b. Enter a manager or representative access code.
- c. At the home menu level, press 3 to access Modem settings.
- d. Press 1 to modify.
- e. Enter a new value.
- f. Press the # button to save the new value.

Customize the Call Out Pre-Delay

Default = 30 minutes

The overall delay value sets the amount of time that the Voice Data Modem will wait before calling down the call out list. If no one on the list answers the Voice Data Modem call out, it will wait this same amount of time before calling down the list again.

For example, let's say the System5F has an alarm event. The Voice Data Modem calls the first person on the list, but there is no answer. It calls the rest of the people on the list. If no one answers, the Voice Data Modem will continue to call out. The delay value establishes a waiting period. If the value is set to 10 minutes, the Voice Data Modem will wait ten minutes after the last call out before it attempts to call down the list again.

To set up the call out phone numbers, use the Strantrol Virtual Controller (SVC) program (from your computer) or access the System5F facepanel using either a Representative or Manager Access Code.

Customize the Delay #1, #2, #3, #4, #5 and #6

Default = 10 seconds

In addition to setting the Overall Delay, you can set the amount of time that the Voice Data Modem waits between dialing each call out number within the list. For example, if no one answers at phone #1, delay #1 tells the Voice Data Modem to wait before calling phone #2.

The FCC and Your Voice Data Modem

Your new USFilter Stranco Products product has been registered with the Federal Communication Commission (FCC). This product complies with standards in Part 68 of the FCC rules. The FCC requires USFilter Stranco Products to provide you with the following information:

Connection and Use With the Nationwide Telephone Network

The FCC requires that you connect your Voice Data Modem to the nationwide telephone network through a modular telephone outlet or jack. The modular telephone outlet or jack to which the telephone equipment must be connected is a USOC RJ-11C or RJ-11W.

This equipment may NOT be used with Party Line Service or with coin telephone lines.

Notification to the Telephone Company

The FCC requires that upon request of you local telephone company, you provide the following information:

- A. The "line" (that is, the phone number) to which you will connect the Voice Data Modem, and
- B. The telephone equipment's FCC registration number and ringer equivalence number (REN). These numbers are on the inside of your controller/telephone equipment.

The REN is useful to determine how many devices you may connect to your telephone line and still having them ring when your telephone line is called. In most areas, the sum of all RENs should be 5 or less. You may want to contact your local telephone company.

Repair Instructions

If it is determined that your Voice Data Modem is malfunctioning, the FCC requires that it not be used and that it be unplugged from the modular outlet until the problem has been corrected. Repairs to this Voice Data Modem equipment can only be made by the manufacturer or its authorized agents or by others who may be authorized by the FCC. For repair procedures, follow the instructions outlined under the USFilter Stranco Products warranty procedure.

Rights of the Telephone Company

If your Voice Data Modem is causing harm to the telephone network, the telephone company may temporarily discontinue your telephone service. If possible, they will notify you before they interrupt service. If advance notice isn't practical, you will be notified as soon as possible. You will be given the opportunity to correct the problem, and you will be informed of your right to file a complaint with the FCC.

Strantrol[®] System5F

Technical Guide

SALES/SERVICE

1.866.766.5987

Fax: 815.932.1760

<http://www.strancoaquatics.com>

e-mail: strancoaquatics@usfilter.com

Products manufactured and marketed by United States Filter Corporation (USFilter) and its affiliates are protected by patents issued or pending in the United States and other countries. USFilter reserves the right to change the specifications referred to in this literature at any time without prior notice. STRANTROL is a trademark of United States Filter Corporation and/or its affiliates.

USFilter

Level 1, 6-10 Talavera Road
North Ryde, NSW 2113
Australia
+61.2.9850.2822 *phone*
+61.2.9850.2898 *fax*

Priory Works, Tonbridge
Kent, TN11 0QL
United Kingdom
+44.(0)1732.354888 *phone*
+44.(0)1732.354222 *fax*

Stranco Products
P.O. Box 389
Bradley, IL 60915 U.S.A.
866.766.5987 *phone*
815.932.8154 *phone*
815.932.1760 *fax*

<http://www.strancoaquatics.com>

© 2003 USFilter

Lit No. ST-System5F-MAN-Rev 0304